

TEST PAPER OF JEE(MAIN) EXAMINATION – 2019
(Held On Wednesday 09th JANUARY, 2019) TIME : 9 : 30 AM To 12 : 30 PM
PHYSICS

1. A current loop, having two circular arcs joined by two radial lines is shown in the figure. It carries a current of 10 A. The magnetic field at point O will be close to :

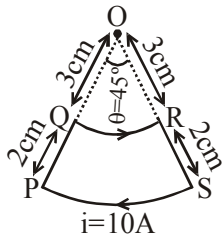

- (1) 1.0×10^{-5} T (2) 1.5×10^{-5} T
 (3) 1.0×10^{-7} T (4) 1.0×10^{-7} T

Ans. (1)

Sol.

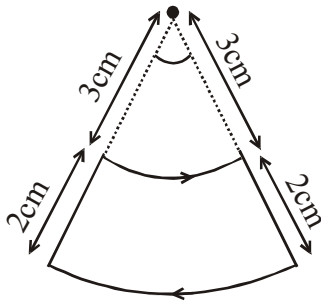

$$\vec{B} = \frac{\mu_0 i}{4\pi} \theta \left[\frac{1}{r_1} - \frac{1}{r_2} \right] \hat{k}$$

$$r_1 = 3 \text{ cm} = 3 \times 10^{-2} \text{ m}$$

$$r_2 = 5 \text{ cm} = 5 \times 10^{-2} \text{ m}$$

$$\theta = \frac{\pi}{4}, i = 10 \text{ A}$$

$$\Rightarrow \vec{B} = \frac{4\pi \times 10^{-7}}{16} \times 10 \left[\frac{1}{3 \times 10^{-2}} - \frac{1}{5 \times 10^{-2}} \right] \hat{k}$$

$$\Rightarrow |\vec{B}| = \frac{\pi}{3} \times 10^{-5} \text{ T}$$

$$\approx 1 \times 10^{-5} \text{ T}$$

2. A gas can be taken from A to B via two different processes ACB and ADB.

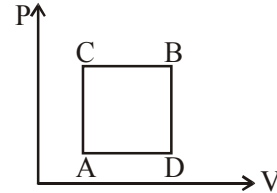

When path ACB is used 60 J of heat flows into the system and 30 J of work is done by the system. If path ADB is used work done by the system is 10 J. The heat flow into the system in path ADB is :
 (1) 80 J (2) 20 J (3) 100 J (4) 40 J

Ans. (4)

Sol.

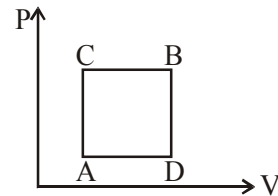

$$\Delta Q_{ACB} = \Delta W_{ACB} + \Delta U_{ACB}$$

$$\Rightarrow 60 \text{ J} = 30 \text{ J} + \Delta U_{ACB}$$

$$\Rightarrow \Delta U_{ACB} = 30 \text{ J}$$

$$\Rightarrow \Delta U_{ADB} = \Delta U_{ACB} = 30 \text{ J}$$

$$\Delta Q_{ACD} = \Delta U_{ACB} + \Delta W_{ADB} = 10 \text{ J} + 30 \text{ J} = 40 \text{ J}$$

3. A plane electromagnetic wave of frequency 50 MHz travels in free space along the positive x-direction. At a particular point in space and time, $\vec{E} = 6.3\hat{j}$ V/m. The corresponding magnetic field \vec{B} , at that point will be:

(1) $18.9 \times 10^{-8} \hat{k}$ T (2) $6.3 \times 10^{-8} \hat{k}$ T

(3) $2.1 \times 10^{-8} \hat{k}$ T (4) $18.9 \times 10^8 \hat{k}$ T

Ans. (3)

Sol. $|\vec{B}| = \frac{|\vec{E}|}{c} = \frac{6.3}{3 \times 10^8} = 2.1 \times 10^{-8} \text{ T}$

and $\hat{E} \times \hat{B} = \hat{C}$

$$\hat{j} \times \hat{B} = \hat{i}$$

$$\hat{B} = \hat{k}$$

$$\vec{B} = |\vec{B}| \hat{B} = 2.1 \times 10^{-8} \hat{k} \text{ T}$$

4. Two coherent sources produce waves of different intensities which interfere. After interference, the ratio of the maximum intensity to the minimum intensity is 16. The intensity of the waves are in the ratio:

- (1) 4 : 1 (2) 25 : 9
 (3) 16 : 9 (4) 5 : 3

Ans. (2)

Sol. $\frac{I_{\max}}{I_{\min}} = 16$

$$\Rightarrow \frac{A_{\max}}{A_{\min}} = 4$$

$$\Rightarrow \frac{A_1 + A_2}{A_1 - A_2} = \frac{4}{1}$$

Using componendo & dividendo.

$$\frac{A_1}{A_2} = \frac{5}{3} \Rightarrow \frac{I_1}{I_2} = \left(\frac{5}{3}\right)^2 = \frac{25}{9}$$

5. An L-shaped object, made of thin rods of uniform mass density, is suspended with a string as shown in figure. If $AB = BC$, and the angle made by AB with downward vertical is θ , then :

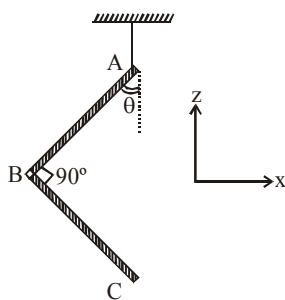

(1) $\tan \theta = \frac{2}{\sqrt{3}}$

(2) $\tan \theta = \frac{1}{3}$

(3) $\tan \theta = \frac{1}{2}$

(4) $\tan \theta = \frac{1}{2\sqrt{3}}$

Ans. (2)

Sol.

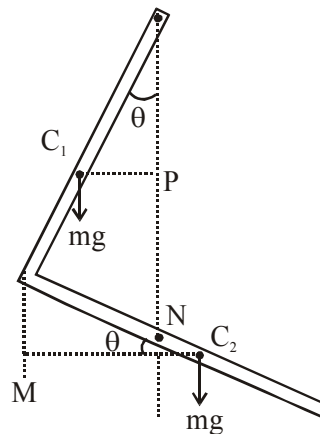

Let mass of one rod is m .
 Balancing torque about hinge point.

$$mg(C_1P) = mg(C_2N)$$

$$mg\left(\frac{L}{2}\sin\theta\right) = mg\left(\frac{L}{2}\cos\theta - L\sin\theta\right)$$

$$\Rightarrow \frac{3}{2}mgL\sin\theta = \frac{mgL}{2}\cos\theta$$

$$\Rightarrow \tan\theta = \frac{1}{3}$$

6. A mixture of 2 moles of helium gas (atomic mass = 4 u), and 1 mole of argon gas (atomic mass = 40 u) is kept at 300 K in a container. The ratio

of their rms speeds $\left[\frac{V_{\text{rms}}(\text{helium})}{V_{\text{rms}}(\text{argon})}\right]$, is close to

- (1) 2.24 (2) 0.45
 (3) 0.32 (4) 3.16

Ans. (4)

Sol. $\frac{V_{\text{rms}}(\text{He})}{V_{\text{rms}}(\text{Ar})} = \sqrt{\frac{M_{\text{Ar}}}{M_{\text{He}}}} = \sqrt{\frac{40}{4}} = 3.16$

7. When the switch S , in the circuit shown, is closed, then the value of current i will be :

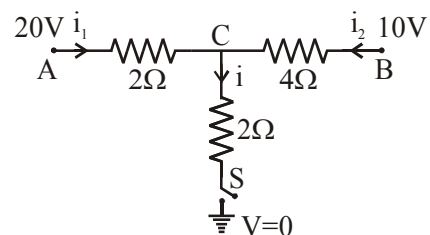

- (1) 3 A (2) 5 A (3) 4 A (4) 2 A

Ans. (2)

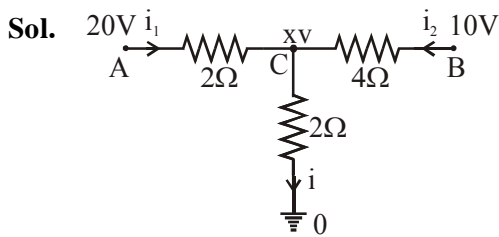

Let voltage at C = xv

KCL : $i_1 + i_2 = i$

$$\frac{20-x}{2} + \frac{10-x}{4} = \frac{x-0}{2}$$

$\Rightarrow x = 10$

and $i = 5$ amp.

8. A resistance is shown in the figure. Its value and tolerance are given respectively by:

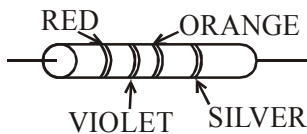

- (1) 27 kΩ, 20% (2) 270 kΩ, 5%
 (3) 270 kΩ, 10% (4) 27 kΩ, 10%

Ans. (4)

Sol. Color code :

Red violet orange silver

$$R = 27 \times 10^3 \Omega \pm 10\%$$

$$= 27 \text{ k}\Omega \pm 10\%$$

9. A bar magnet is demagnetized by inserting it inside a solenoid of length 0.2 m, 100 turns, and carrying a current of 5.2 A. The coercivity of the bar magnet is :

- (1) 1200 A/m (2) 2600 A/m
 (3) 520 A/m (4) 285 A/m

Ans. (2)

Sol. Coercivity = $H = \frac{B}{\mu_0}$

$$= ni = \frac{N}{\ell} i = \frac{100}{0.2} \times 5.2$$

$$= 2600 \text{ A/m}$$

10. A rod, of length L at room temperature and uniform area of cross section A, is made of a metal having coefficient of linear expansion $\alpha/^\circ\text{C}$. It is observed that an external compressive force F, is applied on each of its ends, prevents any change in the length of the rod, when its temperature rises by ΔT K. Young's modulus, Y, for this metal is :

- (1) $\frac{F}{2A\alpha\Delta T}$ (2) $\frac{F}{A\alpha(\Delta T - 273)}$
 (3) $\frac{F}{A\alpha\Delta T}$ (4) $\frac{2F}{A\alpha\Delta T}$

Ans. (3)

Sol. Young's modulus $y = \frac{\text{Stress}}{\text{Strain}}$

$$= \frac{F/A}{(\Delta\ell/\ell)}$$

$$= \frac{F}{A(\alpha\Delta T)}$$

11. A block of mass m, lying on a smooth horizontal surface, is attached to a spring (of negligible mass) of spring constant k. The other end of the spring is fixed, as shown in the figure. The block is initially at rest in its equilibrium position. If now the block is pulled with a constant force F, the maximum speed of the block is :

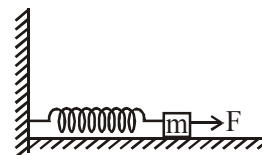

- (1) $\frac{\pi F}{\sqrt{mk}}$ (2) $\frac{2F}{\sqrt{mk}}$
 (3) $\frac{F}{\sqrt{mk}}$ (4) $\frac{F}{\pi\sqrt{mk}}$

Ans. (3)

Sol. Maximum speed is at mean position (equilibrium). $F = kx$

$$x = \frac{F}{k}$$

$$W_F + W_{sp} = \Delta KE$$

$$F(x) - \frac{1}{2}kx^2 = \frac{1}{2}mv^2 - 0$$

$$F\left(\frac{F}{k}\right) - \frac{1}{2}k\left(\frac{F}{k}\right)^2 = \frac{1}{2}mv^2$$

$$\Rightarrow v_{\max} = \frac{F}{\sqrt{mk}}$$

12. Three charges $+Q$, q , $+Q$ are placed respectively, at distance, 0 , $d/2$ and d from the origin, on the x -axis. If the net force experienced by $+Q$, placed at $x=0$, is zero, then value of q is :

- (1) $+Q/2$ (2) $-Q/2$ (3) $-Q/4$ (4) $+Q/4$

Ans. (3)

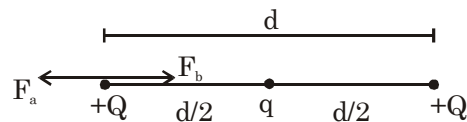

Sol.

For equilibrium,

$$\vec{F}_a + \vec{F}_b = 0$$

$$\vec{F}_a = -\vec{F}_b$$

$$\frac{kQq}{d^2} = -\frac{kQq}{(d/2)^2}$$

$$\Rightarrow q = -\frac{Q}{4}$$

13. A conducting circular loop made of a thin wire, has area $3.5 \times 10^{-3} \text{ m}^2$ and resistance 10Ω . It is placed perpendicular to a time dependent magnetic field

$B(t) = (0.4T)\sin(50\pi t)$. The field is uniform in space. Then the net charge flowing through the loop during $t = 0 \text{ s}$ and $t = 10 \text{ ms}$ is close to:

- (1) 14mC (2) 21 mC (3) 6 mC (4) 7 mC

Ans. (1)

$$\text{Sol. } Q = \frac{\Delta\phi}{R} = \frac{1}{10}A(B_f - B_i) = \frac{1}{10} \times 3.5 \times 10^{-3} \left(0.4\sin\frac{\pi}{2} - 0\right)$$

$$= \frac{1}{10}(3.5 \times 10^{-3})(0.4 - 0)$$

$$= 1.4 \times 10^{-4} = 0.14 \text{ mC}$$

14. Two masses m and $\frac{m}{2}$ are connected at the two ends of a massless rigid rod of length l . The rod is suspended by a thin wire of torsional constant k at the centre of mass of the rod-mass system (see figure). Because of torsional constant k , the restoring torque is $\tau = k\theta$ for angular displacement θ . If the rod is rotated by θ_0 and released, the tension in it when it passes through its mean position will be:

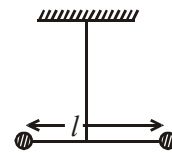

(1) $\frac{3k\theta_0^2}{l}$

(2) $\frac{k\theta_0^2}{2l}$

(3) $\frac{2k\theta_0^2}{l}$

(4) $\frac{k\theta_0^2}{l}$

Ans. (4)

$$\text{Sol. } \omega = \sqrt{\frac{k}{I}}$$

$$\omega = \sqrt{\frac{3k}{m\ell^2}}$$

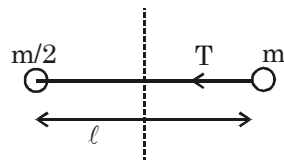

$\Omega = \omega\theta_0 =$ average velocity

$$T = m\Omega^2 r_1$$

$$T = m\Omega^2 \frac{\ell}{3}$$

$$= m\omega^2 \theta_0^2 \frac{\ell}{3}$$

$$= m \frac{3k}{m\ell^2} \theta_0^2 \frac{\ell}{3}$$

$$= \frac{k\theta_0^2}{\ell}$$

$$I = \mu\ell^2 = \frac{2}{3m} \ell^2$$

$$= \frac{m\ell^2}{3}$$

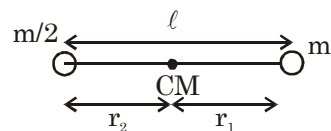

$$\frac{r_1}{r_2} = \frac{1}{2} \Rightarrow r_1 = \frac{\ell}{3}$$

15. A copper wire is stretched to make it 0.5% longer. The percentage change in its electrical resistance if its volume remains unchanged is:
 (1) 2.5% (2) 0.5% (3) 1.0% (4) 2.0%

Ans. (3)

Sol. $R = \frac{\rho\ell}{A}$ and volume $(V) = Al$.

$$R = \frac{\rho\ell^2}{V}$$

$$\Rightarrow \frac{\Delta R}{R} = \frac{2\Delta\ell}{\ell} = 1\%$$

16. A parallel plate capacitor is made of two square plates of side 'a', separated by a distance d ($d \ll a$). The lower triangular portion is filled with a dielectric of dielectric constant K, as shown in the figure.

Capacitance of this capacitor is :

- (1) $\frac{1}{2} \frac{k\epsilon_0 a^2}{d}$ (2) $\frac{k\epsilon_0 a^2}{d} \ln K$
 (3) $\frac{k\epsilon_0 a^2}{d(K-1)} \ln K$ (4) $\frac{k\epsilon_0 a^2}{2d(K+1)}$

Ans. (3)

Sol.

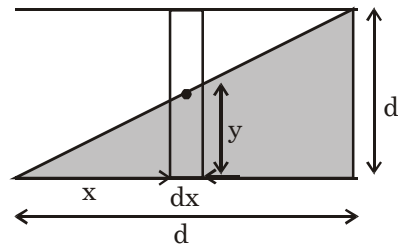

$$\frac{y}{x} = \frac{d}{a}$$

$$y = \frac{d}{a}x$$

$$dy = \frac{d}{a}(dx)$$

$$\frac{1}{dc} = \frac{y}{KE \cdot adx} + \frac{(d-y)}{\epsilon_0 adx}$$

$$\frac{1}{dc} = \frac{1}{\epsilon_0 adx} \left(\frac{y}{k} + d - y \right)$$

$$\int dc = \int \frac{\epsilon_0 adx}{\frac{y}{k} + d - y}$$

$$c = \epsilon_0 a \cdot \frac{a}{d} \int_0^d \frac{dy}{d + y \left(\frac{1}{k} - 1 \right)}$$

$$= \frac{\epsilon_0 a^2}{\left(\frac{1}{k} - 1 \right) d} \left[\ln \left(d + y \left(\frac{1}{k} - 1 \right) \right) \right]_0^d$$

$$= \frac{k\epsilon_0 a^2}{(1-k)d} \ln \left(\frac{d + d \left(\frac{1}{k} - 1 \right)}{d} \right)$$

$$= \frac{k\epsilon_0 a^2}{(1-k)d} \ln \left(\frac{1}{k} \right) = \frac{k\epsilon_0 a^2 \ln k}{(k-1)d}$$

17. Mobility of electrons in a semiconductor is defined as the ratio of their drift velocity to the applied electric field. If, for an n-type semiconductor, the density of electrons is 10^{19}m^{-3} and their mobility is $1.6 \text{ m}^2/(\text{V}\cdot\text{s})$ then the resistivity of the semiconductor (since it is an n-type semiconductor contribution of holes is ignored) is close to:

- (1) $2 \Omega\text{m}$ (2) $0.4 \Omega\text{m}$
 (3) $4 \Omega\text{m}$ (4) $0.2 \Omega\text{m}$

Ans. (2)

Sol. $j = \sigma E = nev_d$

$$\sigma = ne \frac{v_d}{E}$$

$$= ne\mu$$

$$\frac{1}{\sigma} = \rho = \frac{1}{n_e e \mu_e}$$

$$= \frac{1}{10^{19} \times 1.6 \times 10^{-19} \times 1.6}$$

$$= 0.4 \Omega\text{m}$$

18. If the angular momentum of a planet of mass m , moving around the Sun in a circular orbit is L , about the center of the Sun, its areal velocity is :

- (1) $\frac{4L}{m}$ (2) $\frac{L}{m}$ (3) $\frac{L}{2m}$ (4) $\frac{2L}{m}$

Ans. (3)

Sol. $\frac{dA}{dt} = \frac{L}{2m}$

19. A block of mass 10 kg is kept on a rough inclined plane as shown in the figure. A force of 3 N is applied on the block. The coefficient of static friction between the plane and the block is 0.6 . What should be the minimum value of force P , such that the block does not move downward ?

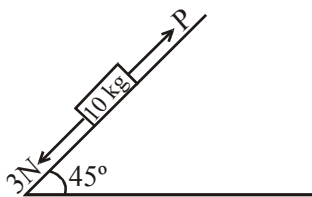

(take $g = 10 \text{ ms}^{-2}$)

- (1) 32 N (2) 25 N (3) 23 N (4) 18 N

Ans. (1)

Sol.

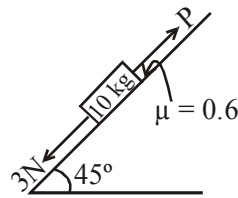

$$mg \sin 45^\circ = \frac{100}{\sqrt{2}} = 50\sqrt{2}$$

$$\mu mg \cos \theta = 0.6 \times mg \times \frac{1}{\sqrt{2}} = 0.6 \times 50\sqrt{2}$$

$$P = 31.28 \approx 32 \text{ N}$$

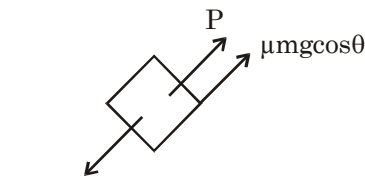

$$73.7 = 3 + mg \sin \theta$$

20. Temperature difference of 120°C is maintained between two ends of a uniform rod AB of length $2L$. Another bent rod PQ, of same cross-section as AB and length $\frac{3L}{2}$, is connected across AB (See figure). In steady state, temperature difference between P and Q will be close to :

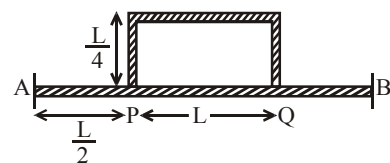

- (1) 60°C (2) 75°C (3) 35°C (4) 45°C

Ans. (4)

Sol.

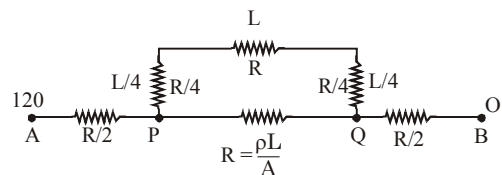

$$\frac{\Delta T}{R_{eq.}} = I = \frac{(120)5}{8R} = \frac{120 \times 5}{8R}$$

$$\Delta T_{PQ} = \frac{120 \times 5}{8R} \times \frac{3}{5} R = \frac{360}{8} = 45^\circ\text{C}$$

21. A heavy ball of mass M is suspended from the ceiling of a car by a light string of mass m ($m \ll M$). When the car is at rest, the speed of transverse waves in the string is 60 ms^{-1} . When the car has acceleration a , the wave-speed increases to 60.5 ms^{-1} . The value of a , in terms of gravitational acceleration g , is closest to :

- (1) $\frac{g}{5}$ (2) $\frac{g}{20}$
 (3) $\frac{g}{10}$ (4) $\frac{g}{30}$

Ans. (1)

Sol. $60 = \sqrt{\frac{Mg}{\mu}}$

$$60.5 = \sqrt{\frac{M(g^2 + a^2)^{1/2}}{\mu}} \Rightarrow \frac{60.5}{60} = \sqrt{\frac{g^2 + a^2}{g^2}}$$

$$\left(1 + \frac{0.5}{60}\right)^4 = \frac{g^2 + a^2}{g^2} = 1 + \frac{2}{60}$$

$$\Rightarrow g^2 + a^2 = g^2 + g^2 \times \frac{2}{60}$$

$$a = g\sqrt{\frac{2}{60}} = \frac{g}{\sqrt{30}} = \frac{g}{5.47}$$

$$\approx \frac{g}{5}$$

22. A sample of radioactive material A, that has an activity of 10 mCi ($1 \text{ Ci} = 3.7 \times 10^{10} \text{ decays/s}$), has twice the number of nuclei as another sample of a different radioactive material B which has an activity of 20 mCi . The correct choices for half-lives of A and B would then be respectively :

- (1) 20 days and 5 days (2) 20 days and 10 days
 (3) 5 days and 10 days (4) 10 days and 40 days

Ans. (1)

Sol. Activity $A = \lambda N$

For A $10 = (2N_0)\lambda_A$

For B $20 = N_0\lambda_B$

$$\therefore \lambda_B = 4\lambda_A \Rightarrow (T_{1/2})_A = 4(T_{1/2})_B$$

23. Consider a tank made of glass (refractive index 1.5) with a thick bottom. It is filled with a liquid of refractive index μ . A student finds that, irrespective of what the incident angle i (see figure) is for a beam of light entering the liquid, the light reflected from the liquid-glass interface is never completely polarized. For this to happen, the minimum value of μ is :

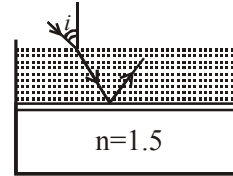

- (1) $\frac{3}{\sqrt{5}}$ (2) $\frac{5}{\sqrt{3}}$ (3) $\sqrt{\frac{5}{3}}$ (4) $\frac{4}{3}$

Ans. (1)

Sol. $C < i_b$

here i_b is "Brewster angle" and c is critical angle

$$\sin c < \sin i_b \quad \text{since } \tan i_b = \mu_{\text{rel}} = \frac{1.5}{\mu}$$

$$\frac{1}{\mu} < \frac{1.5}{\sqrt{\mu^2 + (1.5)^2}} \quad \therefore \sin i_b = \frac{1.5}{\sqrt{\mu^2 + (1.5)^2}}$$

$$\sqrt{\mu^2 \times (1.5)^2} < 1.5 \times \mu$$

$$\mu^2 + (1.5)^2 < (\mu \times 1.5)^2$$

$$\mu < \frac{3}{\sqrt{5}}$$

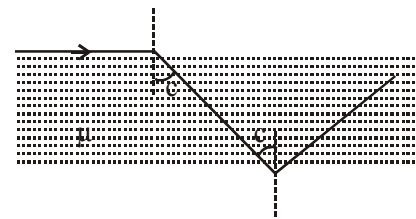

slab $\mu = 1.5$

24. An infinitely long current carrying wire and a small current carrying loop are in the plane of the paper as shown. The radius of the loop is a and distance of its centre from the wire is d ($d \gg a$). If the loop applies a force F on the wire then :

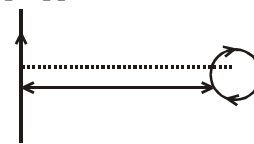

(1) $F \propto \left(\frac{a^2}{d^3}\right)$ (2) $F \propto \left(\frac{a}{d}\right)$

(3) $F \propto \left(\frac{a}{d}\right)^2$ (4) $F = 0$

Ans. (3)

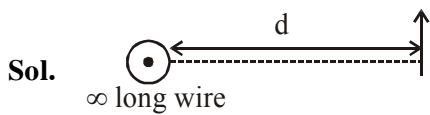

∞ long wire

Eqivalent dipole of given loop

$$F = m \cdot \frac{dB}{dr}$$

$$\text{Now } \frac{dB}{dx} = \frac{d}{dx} \left(\frac{\mu_0 I}{2\pi x} \right)$$

$$\propto \frac{1}{x^2}$$

$$\Rightarrow \text{So } F \propto \frac{M}{x^2} [\because M = NIA]$$

$$\therefore F \propto \frac{a^2}{d^2}$$

25. Surface of certain metal is first illuminated with light of wavelength $\lambda_1 = 350$ nm and then, by light of wavelength $\lambda_2 = 540$ nm. It is found that the maximum speed of the photo electrons in the two cases differ by a factor of 2. The work function of the metal (in eV) is close to :

$$(\text{Energy of photon} = \frac{1240}{\lambda(\text{in nm})} \text{ eV})$$

- (1) 1.8 (2) 1.4 (3) 2.5 (4) 5.6

Ans. (1)

Sol. $\frac{hc}{\lambda_1} = \phi + \frac{1}{2} m (2v)^2$

$$\frac{hc}{\lambda_2} = \phi + \frac{1}{2} mv^2$$

$$\Rightarrow \frac{\frac{hc}{\lambda_1} - \phi}{\frac{hc}{\lambda_2} - \phi} = 4 \Rightarrow \frac{hc}{\lambda_1} - \phi = \frac{4hc}{\lambda_2} - 4\phi$$

$$\Rightarrow \frac{4hc}{\lambda_2} - \frac{hc}{\lambda_1} = 3\phi$$

$$\Rightarrow \phi = \frac{1}{3} hc \left(\frac{4}{\lambda_2} - \frac{1}{\lambda_1} \right)$$

$$= \frac{1}{3} \times 1240 \left(\frac{4 \times 350 - 540}{350 \times 540} \right)$$

$$= 1.8 \text{ eV}$$

26. A particle is moving with a velocity $\vec{v} = K(\hat{y}i + \hat{x}j)$, where K is a constant. The general equation for its path is:

- (1) $xy = \text{constant}$ (2) $y^2 = x^2 + \text{constant}$
 (3) $y = x^2 + \text{constant}$ (4) $y^2 = x + \text{constant}$

Ans. (2)

Sol. $\frac{dx}{dt} = ky, \frac{dy}{dt} = kx$

$$\text{Now, } \frac{dy}{dx} = \frac{\frac{dy}{dt}}{\frac{dx}{dt}} = \frac{x}{y}$$

$$\Rightarrow ydy = xdx$$

Integrating both side

$$y^2 = x^2 + c$$

27. A convex lens is put 10 cm from a light source and it makes a sharp image on a screen, kept 10 cm from the lens. Now a glass block (refractive index 1.5) of 1.5 cm thickness is placed in contact with the light source. To get the sharp image again, the screen is shifted by a distance d. Then d is :

- (1) 0.55 cm away from the lens
 (2) 1.1 cm away from the lens
 (3) 0.55 cm towards the lens
 (4) 0

Ans. (1)

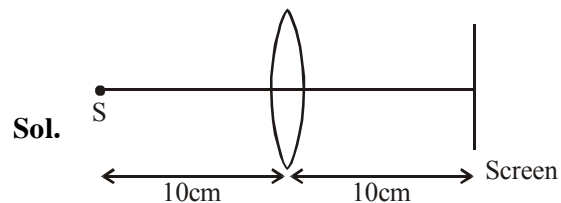

$$\frac{1}{v} - \frac{1}{u} = \frac{1}{f} \Rightarrow \frac{1}{10} - \frac{1}{-10} = \frac{1}{f} \Rightarrow f = 5 \text{ cm}$$

Shift due to slab = $t \left(1 - \frac{1}{\mu} \right)$ in the direction of incident ray

$$= 1.5 \left(1 - \frac{2}{3} \right) = 0.5$$

$$\text{again, } \frac{1}{v} - \frac{1}{-9.5} = \frac{1}{5}$$

$$\Rightarrow \frac{1}{u} = \frac{1}{5} - \frac{2}{19} = \frac{9}{95}$$

$$\Rightarrow v = \frac{95}{9} = 10.55 \text{ cm}$$

28. For a uniformly charged ring of radius R , the electric field on its axis has the largest magnitude at a distance h from its centre. Then value of h is :

- (1) $\frac{R}{\sqrt{5}}$ (2) R (3) $\frac{R}{\sqrt{2}}$ (4) $R\sqrt{2}$

Ans. (3)

Sol. Electric field on axis of ring

$$E = \frac{kQh}{(h^2 + R^2)^{3/2}}$$

for maximum electric field

$$\frac{dE}{dh} = 0$$

$$\Rightarrow h = \frac{R}{\sqrt{2}}$$

29. Three blocks A, B and C are lying on a smooth horizontal surface, as shown in the figure. A and B have equal masses, m while C has mass M . Block A is given an initial speed v towards B due to which it collides with B perfectly inelastically. The combined mass collides with C, also perfectly inelastically $\frac{5}{6}$ th of the initial kinetic energy is lost in whole process. What is value of M/m ?

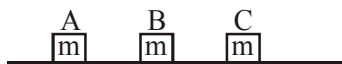

- (1) 4 (2) 5 (3) 3 (4) 2

Ans. (1)

Sol. $k_i = \frac{1}{2}mv_0^2$

From linear momentum conservation

$$mv_0 = (2m + M)v_f$$

$$\Rightarrow v_f = \frac{mv_0}{2m + M}$$

$$\frac{k_i}{k_f} = 6$$

$$\Rightarrow \frac{\frac{1}{2}mv_0^2}{\frac{1}{2}(2m + M)\left(\frac{mv_0}{2m + M}\right)^2} = 6$$

$$\Rightarrow \frac{2m + M}{m} = 6$$

$$\Rightarrow \frac{M}{m} = 4$$

30. Drift speed of electrons, when 1.5 A of current flows in a copper wire of cross section 5 mm^2 , is v . If the electron density in copper is $9 \times 10^{28} / \text{m}^3$ the value of v in mm/s is close to (Take charge of electron to be $=1.6 \times 10^{-19}\text{C}$)

- (1) 0.2 (2) 3
(3) 2 (4) 0.02

Ans. (4)

Sol. $I = neAv_d$

$$\Rightarrow v_d = \frac{I}{neA} = \frac{1.5}{9 \times 10^{28} \times 1.6 \times 10^{-19} \times 5 \times 10^{-6}} = 0.02 \text{ m/s}$$

TEST PAPER OF JEE(MAIN) EXAMINATION – 2019
(Held On Wednesday 09th JANUARY, 2019) TIME : 9 : 30 AM To 12 : 30 PM
CHEMISTRY

1. Which one of the following statements regarding Henry's law not correct ?
- (1) The value of K_H increases with function of the nature of the gas
 - (2) Higher the value of K_H at a given pressure, higher is the solubility of the gas in the liquids.
 - (3) The partial of the gas in vapour phase is proportional to the mole fraction of the gas in the solution.
 - (4) Different gases have different K_H (Henry's law constant) values at the same temperature.

Ans. (2)

Sol. Liquid solution

$$P_{\text{gas}} = K_H \times X_{\text{gas}}$$

More is K_H less is solubility, lesser solubility is at higher temperature. So more is temperature more is K_H .

2. The correct decreasing order for acid strength is :-
- (1) $\text{NO}_2\text{CH}_2\text{COOH} > \text{NCCH}_2\text{COOH} > \text{FCH}_2\text{COOH} > \text{ClCH}_2\text{COOH}$
 - (2) $\text{FCH}_2\text{COOH} > \text{NCCH}_2\text{COOH} > \text{NO}_2\text{CHCOOH} > \text{ClCH}_2\text{COOH}$
 - (3) $\text{NO}_2\text{CH}_2\text{COOH} > \text{FCH}_2\text{COOH} > \text{CNCH}_2\text{COOH} > \text{ClCH}_2\text{COOH}$
 - (4) $\text{CNCH}_2\text{COOH} > \text{O}_2\text{NCH}_2\text{COOH} > \text{FCH}_2\text{COOH} > \text{ClCH}_2\text{COOH}$

Ans. (1)

Sol. EWG increase acidic strength

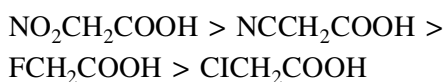

3. Two complexes $[\text{Cr}(\text{H}_2\text{O})_6]\text{Cl}_3$ (A) and $[\text{Cr}(\text{NH}_3)_6]\text{Cl}_3$ (B) are violet and yellow coloured, respectively. The incorrect statement regarding them is :
- (1) Δ_0 value of (A) is less than that of (B).
 - (2) Δ_0 value of (A) and (B) are calculated from the energies of violet and yellow light, respectively
 - (3) Both absorb energies corresponding to their complementary colors.
 - (4) Both are paramagnetic with three unpaired electrons.

Ans. (2)

Sol. Δ_0 order will be compared by spectro chemical series not by energies of violet & yellow light so Δ_0 order is

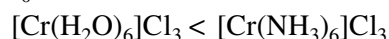

4. Adsorption of a gas follows Freundlich adsorption isotherm. In the given plot, x is the mass of the gas adsorbed on mass m of the adsorbent at pressure p. $\frac{x}{m}$ is proportional to

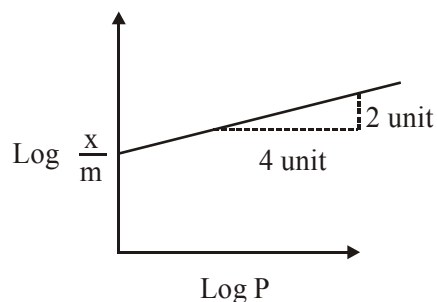

- (1) $P^{\frac{1}{4}}$ (2) P^2 (3) P (4) $P^{1/2}$

Ans. (4)

Sol. $\frac{x}{m} = K \times P^{1/n}$

$$\log \frac{x}{m} = \log K + \frac{1}{n} \log P$$

$$m = \frac{1}{n} = \frac{2}{4} = \frac{1}{2} \Rightarrow n = 2$$

So, $\frac{x}{m} = K \times P^{1/2}$

5. Correct statements among a to d regarding silicones are :

- (a) They are polymers with hydrophobic character
- (b) They are biocompatible.
- (c) In general, they have high thermal stability and low dielectric strength.
- (d) Usually, they are resistant to oxidation and used as greases.

- (1) (a), (b) and (c) only
- (2) (a), and (b) only
- (3) (a), (b), (c) and (d)
- (4) (a), (b) and (d) only

Ans. (3)

Sol. These are properties and uses of silicones.

6. For emission line of atomic hydrogen from $n_i = 8$ to $n_f =$ the plot of wave number $\bar{\nu}$ against $\left(\frac{1}{n^2}\right)$ will be (The Rydberg constant, R_H is in wave number unit).

- (1) Linear with slope - R_H
- (2) Linear with intercept - R_H
- (3) Non linear
- (4) Linear with slope R_H

Ans. (4)

Sol.
$$\frac{1}{\lambda} = \bar{\nu} = R_H Z^2 \left(\frac{1}{\eta_1^2} - \frac{1}{\eta_2^2} \right)$$

$$\bar{\nu} = R_H \times \left(\frac{1}{\eta_1^2} - \frac{1}{8^2} \right)$$

$$\bar{\nu} = R_H \times \frac{1}{\eta^2} - \frac{R_H}{64}$$

$$\bar{\nu} = R_H \times \frac{1}{\eta^2} - \frac{R_H}{64}$$

$$m = R_H$$

Linear with slope R_H

7. The major product the following reaction is :

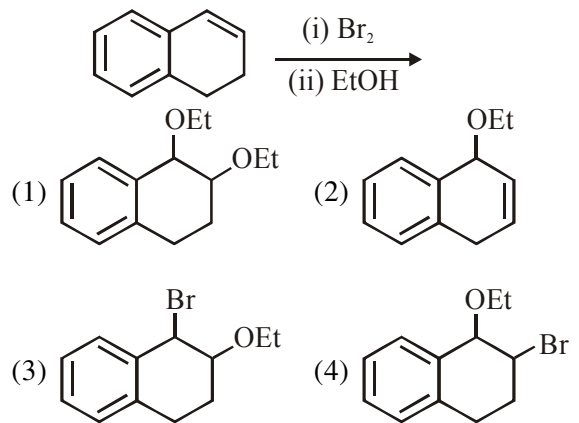

Ans. (4)

Sol.

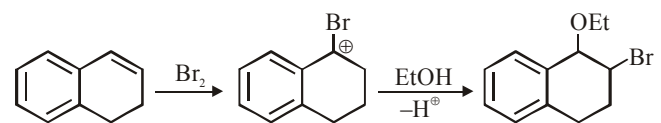

8. The alkaline earth metal nitrate that does not crystallise with water molecules, is :

- (1) $\text{Sr}(\text{NO}_3)_2$
- (2) $\text{Mg}(\text{NO}_3)_2$
- (3) $\text{Ca}(\text{NO}_3)_2$
- (4) $\text{Ba}(\text{NO}_3)_2$

Ans. (4)

Sol. Smaller in size of center atoms more water molecules will crystallize hence $\text{Ba}(\text{NO}_3)_2$ is answer due to its largest size of '+ve' ion.

9. Major product of the following reaction is :

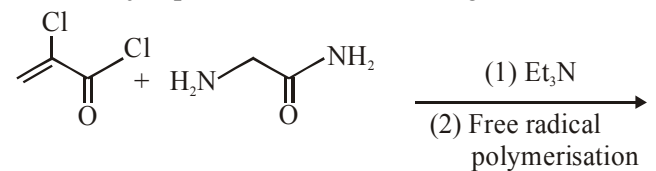

- (1) Copolymer with a chlorine atom in the backbone and a glycine side chain.
- (2) Copolymer with a chlorine atom in the backbone and a glycine side chain, with a different connectivity than (1).
- (3) Copolymer with a chlorine atom in the backbone and a glycine side chain, with a different connectivity than (1) and (2).
- (4) Copolymer with a chlorine atom in the backbone and a glycine side chain, with a different connectivity than (1), (2), and (3).

Ans. (4)

Sol.

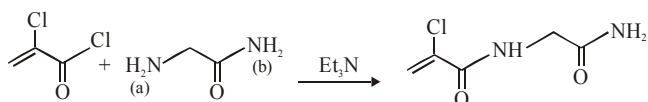

NH₂(a) will react as nucleophile as (b) is having delocalised lonepair.

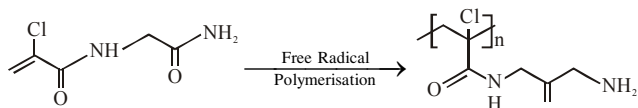

10. The highest value of the calculated spin only magnetic moment (in BM) among all the transition metal complexes is :

- (1) 5.92 (2) 3.87 (3) 6.93 (4) 4.90

Ans. (1)

Sol. $\mu = \sqrt{n(n+2)}$ B.M.

n = Number of unpaired electrons

n = Maximum number of unpaired electron = 5

Ex : Mn²⁺ complex.

11. 20 mL of 0.1 M H₂SO₄ solution is added to 30 mL of 0.2 M NH₄OH solution. The pH of the resultant mixture is : [pK_b of NH₄OH = 4.7].

- (1) 9.4 (2) 5.0 (3) 9.0 (4) 5.2

Ans. (3)

Sol. 20 ml 0.1 M H₂SO₄ $\Rightarrow \eta_{H^+} = 4$

30 ml 0.2 M NH₄OH $\Rightarrow \eta_{NH_4OH} = 6$

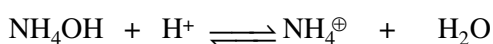

Solution is basic buffer

$$pOH = pK_b + \log \frac{NH_4^+}{NH_4OH}$$

$$= 4.7 + \log 2$$

$$= 4.7 + 0.3 = 5$$

$$pH = 14 - 5 = 9$$

12. 0.5 moles of gas A and x moles of gas B exert a pressure of 200 Pa in a container of volume 10 m³ at 1000 K. given R is the gas constant in JK⁻¹ mol⁻¹m, x is :

- (1) $\frac{2R}{4+12}$ (2) $\frac{2R}{4-R}$ (3) $\frac{4-R}{2R}$ (4) $\frac{4+R}{2R}$

Ans. (3)

Sol. $n_T = (0.5 + x)$

$$PV = n \times R \times T$$

$$200 \times 10 = (0.5 + x) \times R \times 1000$$

$$2 = (0.5 + x) R$$

$$\frac{2}{R} = \frac{1}{2} + x$$

$$\frac{4}{R} - 1 = 2x$$

$$\boxed{\frac{4-R}{2R} = x}$$

13. Consider the reversible isothermal expansion of an ideal gas in a closed system at two different temperatures T₁ and T₂ (T₁ < T₂). The correct graphical depiction of the dependence of work done (w) on the final volume (V) is:

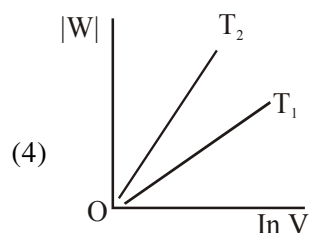
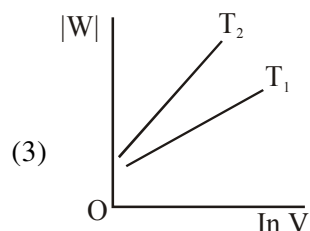
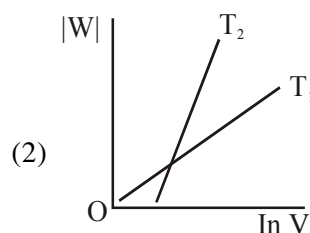
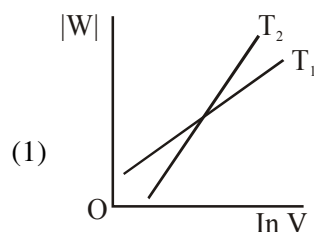

Ans. (2)

Sol. $w = -nRT \ln \frac{V_2}{V_1}$

$$w = -nRT \ln \frac{V_b}{V_i}$$

$$|w| = nRT \ln \frac{V_b}{V_i}$$

$$|w| = nRT (\ln V_b - \ln V_i)$$

$$|w| = nRT \ln V_b - nRT \ln V_i$$

$$Y = m x - C$$

So, slope of curve 2 is more than curve 1 and intercept of curve 2 is more negative than curve 1.

14. The major product of following reaction is :

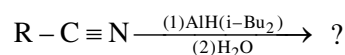

- (1) RCHO (2) RCOOH
(3) RCH₂NH₂ (4) RCONH₂

Ans. (1)

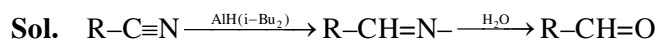

15. In general, the properties that decrease and increase down a group in the periodic table, respectively, are :

- (1) electronegativity and electron gain enthalpy.
(2) electronegativity and atomic radius.
(3) atomic radius and electronegativity.
(4) electron gain enthalpy and electronegativity.

Ans. (2)

Sol. Electronegativity decreases as we go down the group and atomic radius increases as we go down the group.

16. A solution of sodium sulfate contains 92 g of Na⁺ ions per kilogram of water. The molality of Na⁺ ions in that solution in mol kg⁻¹ is:

- (1) 16 (2) 8 (3) 4 (4) 12

Ans. (3)

Sol. $n_{Na^+} = \frac{92}{23} = 4$

So molality = 4

17. A water sample has ppm level concentration of the following metals: Fe= 0.2; Mn = 5.0; Cu = 3.0; Zn = 5.0. The metal that makes the water sample unsuitable drinking is :

- (1) Zn (2) Fe (3) Mn (4) Cu

Ans. (3)

Sol. (i) Zn = 0.2 (ii) Fe = 0.2
(iii) Mn = 5.0 (iv) Cu = 3.0

18. The increasing order of pK_a of the following amino acids in aqueous solution is :

Gly Asp Lys Arg

- (1) Asp < Gly < Arg < Lys
(2) Arg < Lys < Gly < Asp
(3) Gly < Asp < Arg < Lys
(4) Asp < Gly < Lys < Arg

Ans. (1)

Sol. Order of acidic strength :

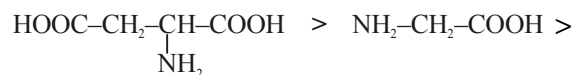

Aspartic acid

Glycine

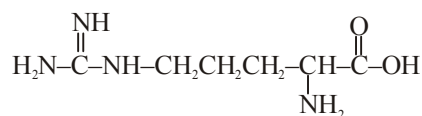

Arginine

So, pK_a

Asp < Gly < Arg < Lys

19. According to molecular orbital theory, which of the following is true with respect to Li₂⁺ and

Li₂⁻?

- (1) Both are unstable
(2) Li₂⁺ is unstable and Li₂⁻ is stable
(3) Li₂⁺ is stable and Li₂⁻ is unstable
(4) Both are stable

Ans. (4)

Sol. Both Li₂⁺ and Li₂⁻ has 0.5 bond order and hence both are stable.

20. The following results were obtained during kinetic studies of the reaction :
 $2A + B \rightarrow \text{Products}$

Experiment	[A] (in mol L ⁻¹)	[B] (in mol L ⁻¹)	Initial Rate of reaction (in mol L ⁻¹ min ⁻¹)
(I)	0.10	0.20	6.93×10^{-3}
(II)	0.10	0.25	6.93×10^{-3}
(III)	0.20	0.30	1.386×10^{-2}

The time (in minutes) required to consume half of A is :

- (1) 10 (2) 5 (3) 100 (4) 1

Ans. (2)

Sol. $6.93 \times 10^{-3} = K \times (0.1)^x (0.2)^y$

$6.93 \times 10^{-3} = K \times (0.1)^x (0.25)^y$

So $y = 0$

and $1.386 \times 10^{-2} = K \times (0.2)^x (0.30)^y$

$$\frac{1}{2} = \left(\frac{1}{2}\right)^x \quad \boxed{x=1}$$

So $r = K \times (0.1) \times (0.2)^0$

$6.93 \times 10^{-3} = K \times 0.1 \times (0.2)^0$

$\boxed{K = 6.93 \times 10^{-2}}$

$$t_{1/2} = \frac{0.693}{2K} = \frac{0.693}{0.693 \times 10^{-1} \times 2} = \frac{10}{2} = 5$$

21. The major product of the following reaction is:

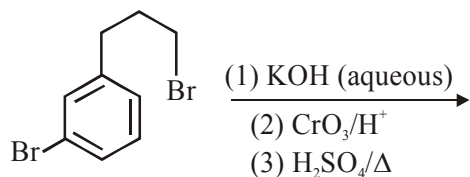

- (1)
- (2)
- (3)
- (4)

Ans. (2)

Sol.

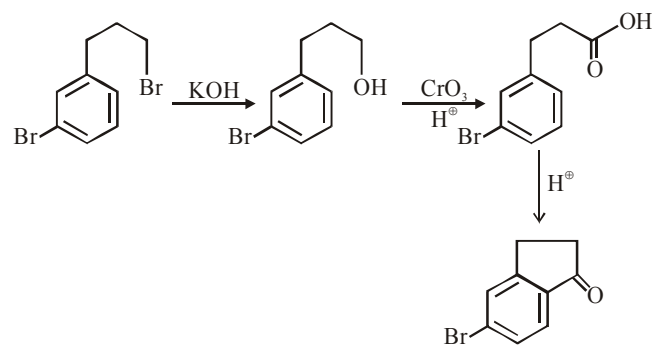

During AES Br is o/p directing and major product will be formed on less hindrance p position :

22. Arrange the following amines in the decreasing order of basicity:

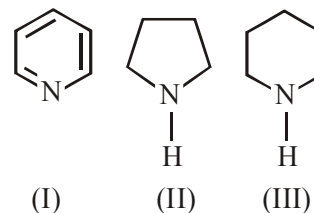

- (1) I > II > III (2) III > II > I
 (3) I > III > II (4) III > I > II

Ans. (4)

Sol. Order of basic strength :

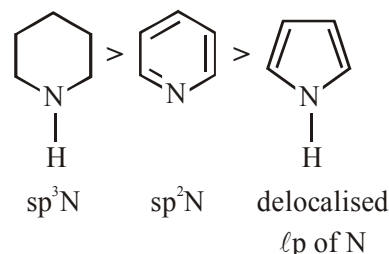

23. Which amongst the following is the strongest acid ?

- (1) CHI₃ (2) CHCl₃
 (3) CHBr₃ (4) CH(CN)₃

Ans. (4)

Sol. CN makes amino most stable so answer is CH(CN)₃

24. The anodic half-cell of lead-acid battery is recharged using electricity of 0.05 Faraday. The amount of PbSO₄ electrolyzed in g during the process in : (Molar mass of PbSO₄ = 303 g mol⁻¹)

- (1) 22.8 (2) 15.2 (3) 7.6 (4) 11.4

Ans. (2)

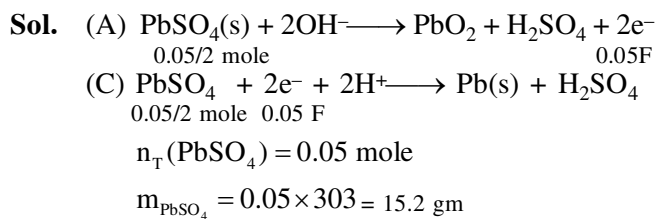

- 25.** The one that is extensively used as a piezoelectric material is :
- (1) Quartz
 - (2) Amorphous silica
 - (3) Mica
 - (4) Tridymite

Ans. (1)

Sol. Quartz (Information)

- 26.** Aluminium is usually found in +3 oxidation stage. In contrast, thallium exists in +1 and +3 oxidation states. This is due to :
- (1) lanthanoid contraction
 - (2) lattice effect
 - (3) diagonal relationship
 - (4) inert pair effect

Ans. (4)

Sol. Inert pair effect is prominent character of p-block element.

- 27.** The correct match between Item -I and Item-II is :

Item - I (drug)		Item - II (test)	
(A)	Chloroxylenol	(P)	Carbylamine Test
(B)	Norethindrone	(Q)	Sodium Hydrogen carbonate Test
(C)	Sulphapyridine	(R)	Ferric chloride test
(D)	Penicillin	(S)	Bayer's test

- (1) A→Q ; B→P ; C→S ; D→R
- (2) A→R ; B→P ; C→S ; D→Q
- (3) A→R ; B→S ; C→P ; D→Q
- (4) A→Q ; B→S ; C→P ; D→R

Ans. (3)

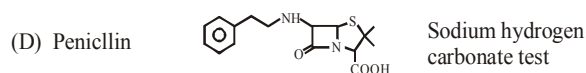
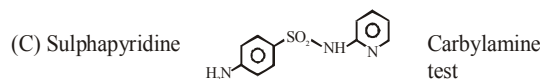
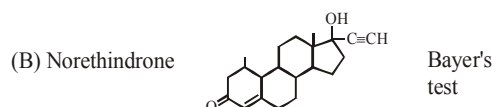
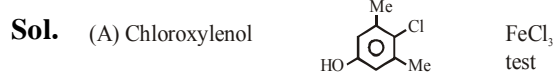

- 28.** The ore that contains both iron and copper is:

- (1) malachite
- (2) dolomite
- (3) azurite
- (4) copper pyrites

Ans. (4)

Sol. Copper pyrites : CuFeS_2

Malachite : $\text{Cu}(\text{OH})_2 \cdot \text{CuCO}_3$

Azurite : $\text{Cu}(\text{OH})_2 \cdot 2\text{CuCO}_3$

Dolomite : $\text{CaCO}_3 \cdot \text{MgCO}_3$

29. The compounds A and B in the following reaction are, respectively:

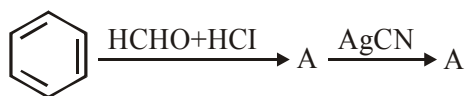

- (1) A = Benzyl alcohol, B = Benzyl isocyanide
 (2) A = Benzyl alcohol, B = Benzyl cyanide
 (3) A = Benzyl chloride, B = Benzyl cyanide
 (4) A = Benzyl chloride, B = Benzyl isocyanide

Ans. (4)

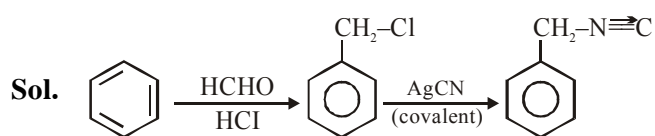

30. The isotopes of hydrogen are :

- (1) Tritium and protium only
 (2) Deuterium and tritium only
 (3) Protium and deuterium only
 (4) Protium, deuterium and tritium

Ans. (4)

Sol. Isotopes of hydrogen is :

Protium Deuterium Tritium

TEST PAPER OF JEE(MAIN) EXAMINATION – 2019
(Held On Wednesday 09th JANUARY, 2019) TIME : 9 : 30 AM To 12 : 30 PM
MATHEMATICS

1. The area (in sq. units) bounded by the parabola $y = x^2 - 1$, the tangent at the point (2, 3) to it and the y-axis is :

- (1) $\frac{14}{3}$ (2) $\frac{56}{3}$ (3) $\frac{8}{3}$ (4) $\frac{32}{3}$

Ans. (3)

Sol.

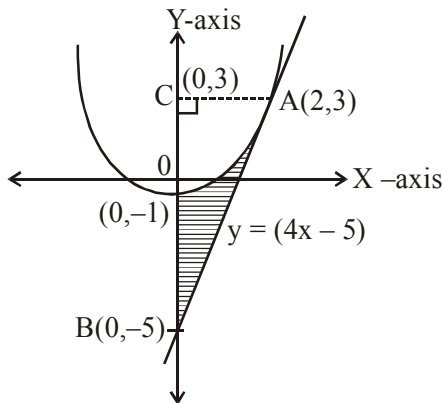

Equation of tangent at (2,3) on $y = x^2 - 1$, is $y = (4x - 5)$ (i)

\therefore Required shaded area

$$\begin{aligned} &= \text{ar}(\Delta ABC) - \int_{-1}^3 \sqrt{y+1} \, dy \\ &= \frac{1}{2} \cdot (8) \cdot (2) - \frac{2}{3} \left((y+1)^{3/2} \right)_{-1}^3 \\ &= 8 - \frac{16}{3} = \frac{8}{3} \text{ (square units)} \end{aligned}$$

2. The maximum volume (in cu. m) of the right circular cone having slant height 3m is :

- (1) $3\sqrt{3} \pi$ (2) 6π
 (3) $2\sqrt{3} \pi$ (4) $\frac{4}{3} \pi$

Ans. (3)

Sol.

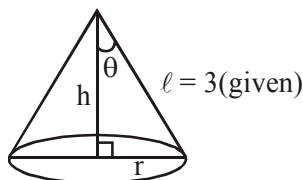

$$\therefore h = 3 \cos \theta$$

$$r = 3 \sin \theta$$

Now,

$$V = \frac{1}{3} \pi r^2 h = \frac{\pi}{3} (9 \sin^2 \theta) \cdot (3 \cos \theta)$$

$$\therefore \frac{dV}{d\theta} = 0 \Rightarrow \sin \theta = \sqrt{\frac{2}{3}}$$

Also, $\left. \frac{d^2V}{d\theta^2} \right|_{\sin \theta = \sqrt{\frac{2}{3}}} = \text{negative}$

\Rightarrow Volume is maximum,

when $\sin \theta = \sqrt{\frac{2}{3}}$

$$\therefore V_{\max} \left(\sin \theta = \sqrt{\frac{2}{3}} \right) = 2\sqrt{3} \pi \text{ (in cu. m)}$$

3. For $x^2 \neq n\pi + 1$, $n \in \mathbb{N}$ (the set of natural numbers), the integral

$$\int x \sqrt{\frac{2 \sin(x^2 - 1) - \sin 2(x^2 - 1)}{2 \sin(x^2 - 1) + \sin 2(x^2 - 1)}} dx$$

is equal to :

(where c is a constant of integration)

(1) $\log_c \left| \sec \left(\frac{x^2 - 1}{2} \right) \right| + c$

(2) $\log_c \left| \frac{1}{2} \sec^2(x^2 - 1) \right| + c$

(3) $\frac{1}{2} \log_c \left| \sec^2 \left(\frac{x^2 - 1}{2} \right) \right| + c$

(4) $\frac{1}{2} \log_c \left| \sec(x^2 - 1) \right| + c$

Ans. (1)

Sol. Put $(x^2 - 1) = t$

$$\Rightarrow 2x dx = dt$$

$$\therefore I = \frac{1}{2} \int \sqrt{\frac{1 - \cos t}{1 + \cos t}} dt$$

$$= \frac{1}{2} \int \tan \left(\frac{t}{2} \right) dt$$

$$= \ln \left| \sec \frac{t}{2} \right| + c$$

$$I = \ln \left| \sec \left(\frac{x^2 - 1}{2} \right) \right| + c$$

4. Let α and β be two roots of the equation $x^2 + 2x + 2 = 0$, then $\alpha^{15} + \beta^{15}$ is equal to :
 (1) 512 (2) -512 (3) -256 (4) 256

Ans. (3)

Sol. We have

$$\begin{aligned} (x + 1)^2 + 1 &= 0 \\ \Rightarrow (x + 1)^2 - (i)^2 &= 0 \\ \Rightarrow (x + 1 + i)(x + 1 - i) &= 0 \end{aligned}$$

$$\therefore x = \underbrace{-(1+i)}_{\alpha(\text{let})} \quad \underbrace{-(1-i)}_{\beta(\text{let})}$$

$$\begin{aligned} \text{So, } \alpha^{15} + \beta^{15} &= (\alpha^2)^7 \alpha + (\beta^2)^7 \beta \\ &= -128(-i + 1 + i + 1) \\ &= -256 \end{aligned}$$

5. If $y = y(x)$ is the solution of the differential equation,

$$x \frac{dy}{dx} + 2y = x^2 \text{ satisfying}$$

$$y(1) = 1, \text{ then } y\left(\frac{1}{2}\right) \text{ is equal to :}$$

- (1) $\frac{7}{64}$ (2) $\frac{13}{16}$ (3) $\frac{49}{16}$ (4) $\frac{1}{4}$

Ans. (3)

Sol. $\frac{dy}{dx} + \left(\frac{2}{x}\right)y = x$

$$\Rightarrow \text{I.F.} = x^2$$

$$\therefore yx^2 = \frac{x^4}{4} + \frac{3}{4} \text{ (As, } y(1) = 1)$$

$$\therefore y\left(x = \frac{1}{2}\right) = \frac{49}{16}$$

6. Equation of a common tangent to the circle, $x^2 + y^2 - 6x = 0$ and the parabola, $y^2 = 4x$, is:

- (1) $2\sqrt{3}y = 12x + 1$
 (2) $2\sqrt{3}y = -x - 12$
 (3) $\sqrt{3}y = x + 3$
 (4) $\sqrt{3}y = 3x + 1$

Ans. (3)

Sol. Let equation of tangent to the parabola $y^2 = 4x$ is

$$\begin{aligned} y &= mx + \frac{1}{m}, \\ \Rightarrow m^2x - ym + 1 &= 0 \text{ is tangent to } x^2 + y^2 - 6x = 0 \end{aligned}$$

$$\Rightarrow \frac{|3m^2 + 1|}{\sqrt{m^4 + m^2}} = 3$$

$$m = \pm \frac{1}{\sqrt{3}}$$

$$\Rightarrow \text{tangent are } x + \sqrt{3}y + 3 = 0$$

$$\text{and } x - \sqrt{3}y + 3 = 0$$

7. Consider a class of 5 girls and 7 boys. The number of different teams consisting of 2 girls and 3 boys that can be formed from this class, if there are two specific boys A and B, who refuse to be the members of the same team, is:
 (1) 200 (2) 300 (3) 500 (4) 350

Ans. (2)

Sol. Required number of ways

$$= \text{Total number of ways} - \text{When A and B are always included.}$$

$$= {}^5C_2 \cdot {}^7C_3 - {}^5C_1 \cdot {}^5C_2 = 300$$

8. Three circles of radii a, b, c ($a < b < c$) touch each other externally. If they have x -axis as a common tangent, then :

$$(1) \frac{1}{\sqrt{a}} = \frac{1}{\sqrt{b}} + \frac{1}{\sqrt{c}}$$

$$(2) a, b, c \text{ are in A. P.}$$

$$(3) \sqrt{a}, \sqrt{b}, \sqrt{c} \text{ are in A. P.}$$

$$(4) \frac{1}{\sqrt{b}} = \frac{1}{\sqrt{a}} + \frac{1}{\sqrt{c}}$$

Ans. (1)

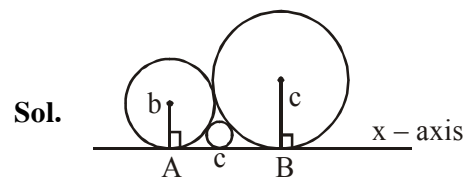

$$AB = AC + CB$$

$$\sqrt{(b+c)^2 - (b-c)^2}$$

$$= \sqrt{(b+a)^2 - (b-a)^2} + \sqrt{(a+c)^2 - (a-c)^2}$$

$$\sqrt{bc} = \sqrt{ab} + \sqrt{ac}$$

$$\frac{1}{\sqrt{a}} = \frac{1}{\sqrt{b}} + \frac{1}{\sqrt{c}}$$

9. If the fractional part of the number $\frac{2^{403}}{15}$ is $\frac{k}{15}$, then k is equal to :

- (1) 14 (2) 6
(3) 4 (4) 8

Ans. (4)

Sol. $\frac{2^{403}}{15} = \frac{2^3 \cdot (2^4)^{100}}{15} = \frac{8}{15}(15+1)^{100}$
 $= \frac{8}{15}(15\lambda + 1) = 8\lambda + \frac{8}{15}$

$\therefore 8\lambda$ is integer

\Rightarrow fractional part of $\frac{2^{403}}{15}$ is $\frac{8}{15} \Rightarrow k = 8$

10. Axis of a parabola lies along x-axis. If its vertex and focus are at distances 2 and 4 respectively from the origin, on the positive x-axis then which of the following points does not lie on it ?

- (1) (4, -4) (2) (5, $2\sqrt{6}$)
(3) (8, 6) (4) $6, 4\sqrt{2}$

Ans. (3)

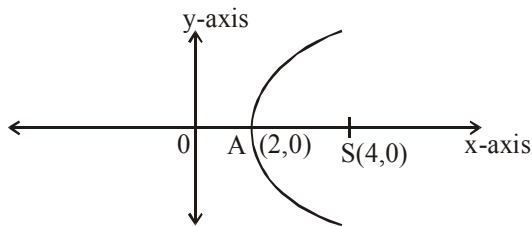

Sol.

equation of parabola is

$$y^2 = 8(x - 2)$$

(8, 6) does not lie on parabola.

11. The plane through the intersection of the planes $x + y + z = 1$ and $2x + 3y - z + 4 = 0$ and parallel to y-axis also passes through the point :

- (1) (-3, 0, -1) (2) (3, 3, -1)
(3) (3, 2, 1) (4) (-3, 1, 1)

Ans. (3)

Sol. Equation of plane

$$(x + y + z - 1) + \lambda(2x + 3y - z + 4) = 0$$

$$\Rightarrow (1 + 2\lambda)x + (1 + 3\lambda)y + (1 - \lambda)z - 1 + 4\lambda = 0$$

dir's of normal of the plane are

$$1 + 2\lambda, 1 + 3\lambda, 1 - \lambda$$

Since plane is parallel to y - axis, $1 + 3\lambda = 0$

$$\Rightarrow \lambda = -1/3$$

So the equation of plane is

$$x + 4z - 7 = 0$$

Point (3, 2, 1) satisfies this equation

Hence Answer is (3)

12. If a, b and c be three distinct real numbers in G. P. and $a + b + c = xb$, then x cannot be :

- (1) 4 (2) -3 (3) -2 (4) 2

Ans. (4)

Sol. $\frac{b}{r}, b, br \rightarrow$ G.P. ($|r| \neq 1$)

given $a + b + c = xb$

$$\Rightarrow b/r + b + br = xb$$

$$\Rightarrow b = 0 \text{ (not possible)}$$

$$\text{or } 1 + r + \frac{1}{r} = x \Rightarrow x - 1 = r + \frac{1}{r}$$

$$\Rightarrow x - 1 > 2 \text{ or } x - 1 < -2$$

$$\Rightarrow x > 3 \text{ or } x < -1$$

So x can't be '2'

13. Consider the set of all lines $px + qy + r = 0$ such that $3p + 2q + 4r = 0$. Which one of the following statements is true ?

- (1) The lines are all parallel.
(2) Each line passes through the origin.

- (3) The lines are not concurrent
The lines are concurrent at the point

(4) $\left(\frac{3}{4}, \frac{1}{2}\right)$

Ans. (4)

Sol. Given set of lines $px + qy + r = 0$

given condition $3p + 2q + 4r = 0$

$$\Rightarrow \frac{3}{4}p + \frac{1}{2}q + r = 0$$

$$\Rightarrow \text{All lines pass through a fixed point } \left(\frac{3}{4}, \frac{1}{2}\right).$$

14. The system of linear equations.

$$x + y + z = 2$$

$$2x + 3y + 2z = 5$$

$$2x + 3y + (a^2 - 1)z = a + 1$$

(1) has infinitely many solutions for $a = 4$

(2) is inconsistent when $|a| = \sqrt{3}$

(3) is inconsistent when $a = 4$

(4) has a unique solution for $|a| = \sqrt{3}$

Ans. (2)

Sol. $D = \begin{vmatrix} 1 & 1 & 1 \\ 2 & 3 & 2 \\ 2 & 3 & a^2 - 1 \end{vmatrix} = a^2 - 3$

$$D_1 = \begin{vmatrix} 2 & 1 & 1 \\ 5 & 3 & 2 \\ a+1 & 3 & a^2 - 1 \end{vmatrix} = a^2 - a + 1$$

$$D_2 = \begin{vmatrix} 1 & 2 & 1 \\ 2 & 5 & 2 \\ 2 & a+1 & a^2 - 1 \end{vmatrix} = a^2 - 3$$

$$D_3 = \begin{vmatrix} 1 & 1 & 2 \\ 2 & 3 & 5 \\ 2 & 3 & a+1 \end{vmatrix} = a - 4$$

$D = 0$ at $|a| = \sqrt{3}$ but $D_3 = \pm\sqrt{3} - 4 \neq 0$

So the system is Inconsistent for $|a| = \sqrt{3}$

15. Let $\vec{a} = \hat{i} - \hat{j}$, $\vec{b} = \hat{i} + \hat{j} + \hat{k}$ and \vec{c} be a vector such that $\vec{a} \times \vec{c} + \vec{b} = \vec{0}$ and $\vec{a} \cdot \vec{c} = 4$, then $|\vec{c}|^2$ is equal to :-

- (1) $\frac{19}{2}$ (2) 8 (3) $\frac{17}{2}$ (4) 9

Ans. (1)

Sol. $\vec{a} \times \vec{c} = -\vec{b}$

$$(\vec{a} \times \vec{c}) \times \vec{a} = -\vec{b} \times \vec{a}$$

$$\Rightarrow (\vec{a} \times \vec{c}) \times \vec{a} = \vec{a} \times \vec{b}$$

$$\Rightarrow (\vec{a} \cdot \vec{a})\vec{c} - (\vec{c} \cdot \vec{a})\vec{a} = \vec{a} \times \vec{b}$$

$$\Rightarrow 2\vec{c} - 4\vec{a} = \vec{a} \times \vec{b}$$

Now $\vec{a} \times \vec{b} = \begin{vmatrix} \hat{i} & \hat{j} & \hat{k} \\ 1 & -1 & 0 \\ 1 & 1 & 1 \end{vmatrix} = -\hat{i} - \hat{j} + 2\hat{k}$

$$\text{So, } 2\vec{c} = 4\hat{i} - 4\hat{j} - \hat{i} - \hat{j} + 2\hat{k} \\ = 3\hat{i} - 5\hat{j} + 2\hat{k}$$

$$\Rightarrow \vec{c} = \frac{3}{2}\hat{i} - \frac{5}{2}\hat{j} + \hat{k}$$

$$|\vec{c}| = \sqrt{\frac{9}{4} + \frac{25}{4} + 1} = \sqrt{\frac{38}{4}} = \sqrt{\frac{19}{2}}$$

$$|\vec{c}|^2 = \frac{19}{2}$$

16. Let a_1, a_2, \dots, a_{30} be an A. P., $S = \sum_{i=1}^{30} a_i$ and

$T = \sum_{i=1}^{15} a_{(2i-1)}$. If $a_5 = 27$ and $S - 2T = 75$, then a_{10} is equal to :

- (1) 57 (2) 47 (3) 42 (4) 52

Ans. (4)

Sol. $S = a_1 + a_2 + \dots + a_{30}$

$$S = \frac{30}{2}[a_1 + a_{30}]$$

$$S = 15(a_1 + a_{30}) = 15(a_1 + a_1 + 29d)$$

$$T = a_1 + a_3 + \dots + a_{29} \\ = (a_1) + (a_1 + 2d) + \dots + (a_1 + 28d) \\ = 15a_1 + 2d(1 + 2 + \dots + 14)$$

$$T = 15a_1 + 210d$$

Now use $S - 2T = 75$

$$\Rightarrow 15(2a_1 + 29d) - 2(15a_1 + 210d) = 75$$

$$\Rightarrow d = 5$$

Given $a_5 = 27 = a_1 + 4d \Rightarrow a_1 = 7$

Now $a_{10} = a_1 + 9d = 7 + 9 \times 5 = 52$

17. 5 students of a class have an average height 150 cm and variance 18 cm². A new student, whose height is 156 cm, joined them. The variance (in cm²) of the height of these six students is:

- (1) 22 (2) 20 (3) 16 (4) 18

Ans. (2)

Sol. Given $\bar{x} = \frac{\sum X_i}{5} = 150$

$$\Rightarrow \sum_{i=1}^5 X_i = 750 \quad \dots(i)$$

$$\frac{\sum X_i^2}{5} - (\bar{x})^2 = 18$$

$$\frac{\sum X_i^2}{5} - (150)^2 = 18$$

$$\sum X_i^2 = 112590 \quad \dots(ii)$$

Given height of new student

$$x_6 = 156$$

$$\text{Now, } \bar{x}_{\text{new}} = \frac{\sum_{i=1}^6 X_i}{6} = \frac{750 + 156}{6} = 151$$

$$\text{Also, New variance} = \frac{\sum_{i=1}^6 X_i^2}{6} - (\bar{x}_{\text{new}})^2$$

$$= \frac{112590 + (156)^2}{6} - (151)^2 \\ = 22821 - 22801 = 20$$

25. For any $\theta \in \left(\frac{\pi}{4}, \frac{\pi}{2}\right)$, the expression

$3(\sin\theta - \cos\theta)^4 + 6(\sin\theta + \cos\theta)^2 + 4\sin^6\theta$ equals :

- (1) $13 - 4 \cos^6\theta$
 (2) $13 - 4 \cos^4\theta + 2 \sin^2\theta \cos^2\theta$
 (3) $13 - 4 \cos^2\theta + 6 \cos^4\theta$
 (4) $13 - 4 \cos^2\theta + 6 \sin^2\theta \cos^2\theta$

Ans. (1)

Sol. We have,

$$\begin{aligned} & 3(\sin\theta - \cos\theta)^4 + 6(\sin\theta + \cos\theta)^2 + 4\sin^6\theta \\ &= 3(1 - \sin 2\theta)^2 + 6(1 + \sin 2\theta) + 4\sin^6\theta \\ &= 3(1 - 2\sin 2\theta + \sin^2 2\theta) + 6 + 6\sin 2\theta + 4\sin^6\theta \\ &= 9 + 12\sin 2\theta \cdot \cos^2\theta + 4(1 - \cos^2\theta)^3 \\ &= 13 - 4\cos^6\theta \end{aligned}$$

26. If $\cos^{-1}\left(\frac{2}{3x}\right) + \cos^{-1}\left(\frac{3}{4x}\right) = \frac{\pi}{2}$ ($x > \frac{3}{4}$)

then x is equal to :

- (1) $\frac{\sqrt{145}}{12}$ (2) $\frac{\sqrt{145}}{10}$
 (3) $\frac{\sqrt{146}}{12}$ (4) $\frac{\sqrt{145}}{11}$

Ans. (1)

Sol. $\cos^{-1}\left(\frac{2}{3x}\right) + \cos^{-1}\left(\frac{3}{4x}\right) = \frac{\pi}{2}$ ($x > \frac{3}{4}$)

$$\cos^{-1}\left(\frac{3}{4x}\right) = \frac{\pi}{2} - \cos^{-1}\left(\frac{2}{3x}\right)$$

$$\cos^{-1}\left(\frac{3}{4x}\right) = \sin^{-1}\left(\frac{2}{3x}\right)$$

$$\cos\left(\cos^{-1}\left(\frac{3}{4x}\right)\right) = \cos\left(\sin^{-1}\frac{2}{3x}\right)$$

$$\frac{3}{4x} = \frac{\sqrt{9x^2 - 4}}{3x}$$

$$\frac{81}{16} + 4 = 9x^2$$

$$x^2 = \frac{145}{16 \times 9} \Rightarrow x = \frac{\sqrt{145}}{12}$$

27. The value of $\int_0^{\pi} |\cos x|^3 dx$

- (1) $2/3$ (2) 0
 (3) $-4/3$ (4) $4/3$

Ans. (4)

$$\begin{aligned} \text{Sol. } \int_0^{\pi} |\cos x|^3 dx &= \int_0^{\pi/2} \cos^3 x dx - \int_{\pi/2}^{\pi} \cos^3 x dx \\ &= \int_0^{\pi/2} \left(\frac{\cos 3x + 3\cos x}{4}\right) dx - \int_{\pi/2}^{\pi} \left(\frac{\cos 3x + 3\cos x}{4}\right) dx \\ &= \frac{1}{4} \left[\left(\frac{\sin 3x}{3} + 3\sin x\right)_0^{\pi/2} - \left(\frac{\sin 3x}{3} + 3\sin x\right)_{\pi/2}^{\pi} \right] \\ &= \frac{1}{4} \left[\left(\frac{-1}{3} + 3\right) - (0+0) - \left\{ (0+0) - \left(\frac{-1}{3} + 3\right) \right\} \right] \\ &= \frac{4}{3} \end{aligned}$$

28. If the Boolean expression

$(p \oplus q) \wedge (\sim p \odot q)$ is equivalent to $p \wedge q$, where $\oplus, \odot \in \{\wedge, \vee\}$, then the ordered pair (\oplus, \odot) is:

- (1) (\wedge, \vee)
 (2) (\vee, \vee)
 (3) (\wedge, \wedge)
 (4) (\vee, \wedge)

Ans. (1)

Sol. $(p \oplus q) \wedge (\sim p \square q) \equiv p \wedge q$ (given)

p	q	$\sim p$	$p \wedge q$	$p \vee q$	$\sim p \vee q$	$\sim p \wedge q$	$(p \wedge q) \wedge (\sim p \vee q)$
T	T	F	T	T	T	F	T
T	F	F	F	T	F	F	F
F	T	T	F	T	T	T	F
F	F	T	F	F	T	F	F

from truth table $(\oplus, \square) = (\wedge, \vee)$

29. $\lim_{y \rightarrow 0} \frac{\sqrt{1+\sqrt{1+y^4}} - \sqrt{2}}{y^4}$

(1) exists and equals $\frac{1}{4\sqrt{2}}$

(2) does not exist

(3) exists and equals $\frac{1}{2\sqrt{2}}$

(4) exists and equals $\frac{1}{2\sqrt{2}(\sqrt{2}+1)}$

Ans. (1)

Sol. $\lim_{y \rightarrow 0} \frac{\sqrt{1+\sqrt{1+y^4}} - \sqrt{2}}{y^4}$

$$= \lim_{y \rightarrow 0} \frac{1 + \sqrt{1+y^4} - 2}{y^4 (\sqrt{1+\sqrt{1+y^4}} + \sqrt{2})}$$

$$= \lim_{y \rightarrow 0} \frac{(\sqrt{1+y^4} - 1)(\sqrt{1+y^4} + 1)}{y^4 (\sqrt{1+\sqrt{1+y^4}} + \sqrt{2})(\sqrt{1+y^4} + 1)}$$

$$= \lim_{y \rightarrow 0} \frac{1+y^4 - 1}{y^4 (\sqrt{1+\sqrt{1+y^4}} + \sqrt{2})(\sqrt{1+y^4} + 1)}$$

$$= \lim_{y \rightarrow 0} \frac{1}{(\sqrt{1+\sqrt{1+y^4}} + \sqrt{2})(\sqrt{1+y^4} + 1)} = \frac{1}{4\sqrt{2}}$$

30. Let $f : \mathbb{R} \rightarrow \mathbb{R}$ be a function defined as :

$$f(x) = \begin{cases} 5, & \text{if } x \leq 1 \\ a + bx, & \text{if } 1 < x < 3 \\ b + 5x, & \text{if } 3 \leq x < 5 \\ 30, & \text{if } x \geq 5 \end{cases}$$

Then, f is :

(1) continuous if $a = 5$ and $b = 5$

(2) continuous if $a = -5$ and $b = 10$

(3) continuous if $a = 0$ and $b = 5$

(4) not continuous for any values of a and b

Ans. (4)

Sol. $f(x) = \begin{cases} 5 & \text{if } x \leq 1 \\ a + bx & \text{if } 1 < x < 3 \\ b + 5x & \text{if } 3 \leq x < 5 \\ 30 & \text{if } x \geq 5 \end{cases}$

$$f(1) = 5, \quad f(1^-) = 5, \quad f(1^+) = a + b$$

$$f(3^-) = a + 3b, \quad f(3) = b + 15, \quad f(3^+) = b + 15$$

$$f(5^-) = b + 25; \quad f(5) = 30 \quad f(5^+) = 30$$

from above we concluded that f is not continuous for any values of a and b .