

**CBSE**  
**Class X Science**  
**Board Paper – 2018 (Set 2)**

**Time allowed: 3 hours**

**Maximum marks: 80**

---

**General Instructions:**

1. The question paper comprises of two **Sections, A and B**. You are to attempt both the sections.
  2. All questions are compulsory.
  3. All questions of **Section A** and **Section B** are to be attempted separately.
  4. There is an internal choice in **three** questions of **three** marks each, **two** questions of **five** marks each in Section A and in **one** question of **two** marks in Section B.
  5. Question numbers **1** and **2** in **Section A** are **one mark** questions. These are to be answered in one word or in **one** sentence.
  6. Question numbers **3** to **5** in **Section A** are **two marks** questions. These are to be answered in about **30 words each**.
  7. Question numbers **6** to **15** in **Section A** are **three marks** questions. These are to be answered in about **50 words each**.
  8. Question numbers **16** to **21** in **Section A** are **five marks** questions. These are to be answered in about **70 words each**.
  9. Question numbers **22** to **27** in **Section B** are based on practical skills. Each question is a **two marks** question. These are to be answered in brief.
- 

**SECTION A**

1. Write the energy conversion that takes place in a hydropower plant. [1]
2. A Mendelian experiment consisted of breeding pea plants bearing violet flowers with pea plant bearing white flowers. What will be the result in F<sub>1</sub> progeny? [1]
3. [2]
  - (a) Name one gustatory receptor and one olfactory receptor present in human beings.
  - (b) Write a and b in the given flow chart of neuron through which information travels as an electrical impulse.



4. If the image formed by a spherical mirror of all positions of the object placed in front of it is always erect and diminished, what type of mirror is it? Draw a labelled ray diagram to support your answer. [2]
5. A compound 'X' on heating with excess conc. sulphuric acid at 443 K gives an unsaturated compound 'Y'. 'X' also reacts with sodium metal to evolve a colourless gas 'Z'. Identify 'X', 'Y' and 'Z'. Write the equation of the chemical reaction of formation of 'Y' and also write the role of sulphuric acid in the reaction. [2]
6. State the laws of refraction of light. Explain the term 'absolute refractive index of a medium' and write an expression to relate it with the speed of light in vacuum. [3]

**OR**

What is meant by power of a lens? Write its SI unit. A student uses a lens of focal length 40 cm and another of -20 cm. Write the nature and power of each lens. [3]

7. Write one main difference between asexual and sexual mode of reproduction. Which species is likely to have comparatively better chances of survival – the one reproducing asexually or the one reproducing sexually? Give reason to justify your answer. [3]
8. Show how would you join three resistors, each of resistance  $9\ \Omega$  so that the equivalent resistance of the combination is (i)  $13.5\ \Omega$  (ii)  $6\ \Omega$ ? [3]

**OR**

(a) Write Joule's law of heating.

(b) Two lamps, one rated 100 W; 220 V, and the other 60 W; 220 V, are connected in parallel to electric mains supply. Find the current drawn by two bulbs from the line, if the supply voltage is 220V.

9. Name the hormones secreted by the following endocrine glands and specify one function of each: [3]  
(a) Thyroid (b) Pituitary (c) Pancreas

10. 2 mL of sodium hydroxide solution is added to a few pieces of granulated zinc metal taken in a test tube. When the contents are warmed, a gas evolves which is bubbled through a soap solution before testing. Write the equation of the chemical reaction involved and the test to detect the gas. Name the gas which will be evolved when the same metal reacts with dilute solution of a strong acid. [3]

**OR**

The pH of a salt used to make tasty and crispy pakoras is 14. Identify the salt and write a chemical equation for its formation. List its two uses.

- 11.** [3]
- (a) Why are most carbon compounds poor conductors of electricity?
- (b) Write the name and structure of saturated compounds in which the carbon atoms are arranged in a ring. Give the number of single bonds present in this compound.
- 12.** Decomposition reactions require energy either in the form of heat or light or electricity for breaking down the reactants. Write one equation each for decomposition reactions where energy is supplied in the form of heat, light and electricity. [3]
- 13.** What is a dam? Why do we seek to build large dams? While building large dams, which three main problems should particularly be addressed to maintain peace among local people? Mention them. [3]
- 14.** Students in a school listened to the news read in the morning assembly that the mountain of garbage in Delhi. Suddenly exploded and various vehicles got buried under it. Several people were also injured and there was traffic jam all around. In the brain storming session the teacher also discussed this issue and asked the students to find out a solution to the problem of garbage. Finally they arrived at two main points – one is self-management of the garbage we produce and the second is to generate less garbage at individual level.
- (a) Suggest two measures to manage the garbage we produce.
- (b) As an individual, what can we do to generate the least garbage? Give two points.
- (c) List two values the teacher instilled in his students in this episode.
- 15.** [3]
- (a) List the factors on which the resistance of a conductor in the shape of a wire depends.
- (b) Why are metals good conductors of electricity whereas glass is a bad conductor of electricity? Give reasons.
- (c) Why are alloys commonly used in electrical heating devices? Give reasons.
- 16.** [5]
- (a) State Fleming's left hand rule.
- (b) Write the principle of working of an electric motor.
- (c) Explain the function of the following parts of an electric motor.  
(i) Armature (ii) Brushes (iii) Split ring
- 17.** [5]
- (a) Write the function of following parts in human female reproductive system:  
(i) Ovary (ii) Oviduct (iii) Uterus
- (b) Describe in brief the structure and function of placenta.

18. [5]
- (a) Write the steps involved in the extraction of pure metals in the middle of the activity series from their carbonate ores.
  - (b) How is copper extracted from its sulphide ore? Explain the various steps supported by chemical equations. Draw labelled diagram for the electrolytic refining of copper.

19. [5]
- (a) Mention any two components of blood.
  - (b) Trace the movement of oxygenated blood in the body.
  - (c) Write the function of valves present in between atria and ventricles.
  - (d) Write one structural difference between the composition of artery and veins.

**OR**

- (a) Define excretion.
- (b) Name the basic filtration unit present in the kidney.
- (c) Draw excretory system in human beings and label the following organs of excretory system which perform following functions :
  - (i) form urine.
  - (ii) is a long tube which collects urine from kidney.
  - (iii) store urine until it is passed out.

20. [5]
- (a) The modern periodic table has been evolved through the early attempts of Dobereiner, Newland and Mendeleev. List one advantage and one limitation of all the three attempts.
  - (b) Name the scientist who first of all showed that atomic number of an element is a more fundamental property than its atomic mass.
  - (c) State Modern periodic law.

21. [5]
- (a) A student is unable to see clearly the words written on the black board placed at a distance of approximately 3 m from him. Name the defect of vision the boy is suffering from. State the possible causes of this defect and explain the method of correcting it.
  - (b) Why do stars twinkle? Explain.

**OR**

- (a) Write the function of each of the following parts of human eye:
  - (i) Cornea (ii) Iris (iii) Crystalline lens (iv) Ciliary muscles
- (b) Why does the sun appear reddish early in the morning? Will this phenomenon be observed by an astronaut on the Moon? Give reason to justify your answer.

### SECTION - B

22. Name the process by which an amoeba reproduces. Draw the various stages of its reproduction in a proper sequence. [2]

OR

A student is viewing under a microscope a permanent slide showing various stages of sexual reproduction by budding in yeast. Draw diagrams of what he observes (in proper sequence).

23. An object of height 4.0 cm is placed at a distance of 30 cm from the optical centre 'O' of a convex lens of focal length 20 cm. Draw a ray diagram to find the position and size of the image formed. Mark optical centre 'O' and principal focus 'F' on the diagram. Also find the approximate ratio of size of the image to the size of the object. [2]

24. A student added few pieces of aluminum metal in two test tubes A and B containing aqueous solutions of iron sulphate and copper sulphate. In the second part of her experiment, she added iron metal to another test tubes C and D containing aqueous solutions of aluminum sulphate and copper sulphate. In which test tube or test tubes will she observe color change? On the basis of this experiment, state which one is the most reactive metal and why. [2]

25. What is observed when a solution of sodium sulphate is added to a solution of barium chloride taken in a test tube? Write equation for the chemical reaction involved and name the type of reaction in this case. [2]

26. The values of current (I) flowing through a given resistor of resistance (R), for the corresponding values of potential difference (V) across the resistor are as given below: [2]

V (Volts)	0.5	1.0	1.5	2.0	2.5	3.0	4.0	5.0
I (amperes)	0.1	0.2	0.3	0.4	0.5	0.6	0.8	1.0

Plot a graph between current (I) and potential difference (V) and determine the resistance (R) of the resistor.

27. List the steps preparation of temporary mount of a leaf peel to observe stomata. [2]

**CBSE**  
**Class X Science**  
**Board Paper - 2018 (Set 2) Solution**

---

**Section A**

1. Energy conversion at a hydroelectric power plant is as follows:  
Kinetic energy of flowing river water → Potential energy of water stored in a reservoir at a height of a dam → Kinetic energy of water flowing from the height on the blades of a turbine → Electrical energy
2. The  $F_1$  progeny would bear violet flowers as violet colour is a dominant character over white colour.
3. (a)  
Gustatory receptors are located on the tongue. They help to detect taste.  
The olfactory receptors are located in the nose. They help to detect smell.

(b)

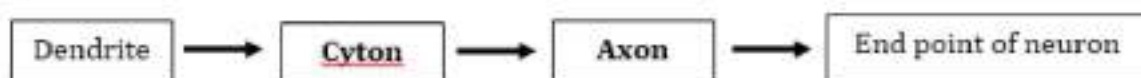

4. The image formed by a convex mirror is always virtual, erect and diminished, irrespective of the position of the object. Hence, the mirror is a convex mirror.

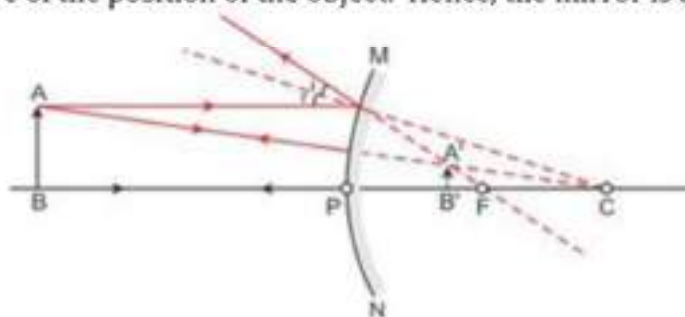

*Object anywhere between  
infinity and P*

5. X is ethanol.  
Y is ethene.  
Z is hydrogen gas.  
When ethanol is heated with excess amount of concentrated sulphuric acid, it gives an unsaturated compound ethene ( $C_2H_4$ ).  
Conc.  $H_2SO_4$  acts as a dehydrating agent because it ejects water from ethanol.

Reaction:

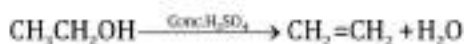

Now, when ethanol reacts with sodium, a colourless gas is evolved, which is hydrogen gas.

Reaction:



## 6. **Laws of refraction of light:**

a) The incident ray, the refracted ray and the normal to the interface of two media at the point of incidence, all lie in the same plane.

b) The ratio of the sine of the angle of incidence to the sine of the angle of refraction is constant for a given pair of media.

$$\frac{\sin i}{\sin r} = \text{constant} = {}^1n_2 = \frac{n_2}{n_1}$$

This law is also known as **Snell's law**.

The constant, written as  ${}^1n_2$ , is called the **refractive index** of the second medium with respect to the first medium.

### **Absolute refractive index of a medium:**

When a beam of light is going from vacuum to another medium, the value of the refractive index is called absolute refractive index.

The refractive index of vacuum (air) is always 1. The absolute refractive index is denoted by the symbol  $n_2$ .

$$n_2 = \frac{\text{Refractive index of medium}}{\text{Refractive index of vacuum (air)}} = \frac{\text{speed of light in vacuum}}{\text{speed of light in the medium}} = \frac{c}{v}$$

$$\therefore n_2 = \frac{c}{v}$$

**OR**

### **Power of lens:**

The power of a lens is the measure of degree of convergence or divergence of light rays falling on it.

The SI unit of power of a lens is dioptre denoted by 'D'.

The power of a lens is given by

$$P = \frac{1}{f \text{ (in metres)}}$$

∴ For lens of focal length 40 cm,  $f = 0.4 \text{ m}$

$$\therefore P = \frac{1}{0.4} = +2.5 \text{ D}$$

The lens is convex lens and is used to correct hypermetropia.

For lens of focal length -20 cm,  $f = 0.2 \text{ m}$

$$\therefore P = \frac{1}{-0.2} = -5.0 \text{ D}$$

The lens is concave lens and is used to correct myopia.

7.

- In asexual reproduction, only a single parent is involved, which divides and gives rise to new individuals. These individuals are exactly identical to the parent organism, and hence, there is a minimal change in their genetic constitution.
- In sexual reproduction, two different parents are involved. Both parents produce two different kinds of gametes which fuse to give rise to a new individual. Because of the fusion of gametes, the new individual has a different genetic constitution and does not entirely resemble the parents.
- Organisms which reproduce by sexual reproduction comparatively have better chances of survival than those reproducing asexually. This is because sexual reproduction involves the fusion of two different types of gametes obtained from two different individuals. This result in genetic recombination leads to a greater genetic diversity, and thus, better chances to adapt, escape or evolve through selection pressure of nature.

8. Consider the resistors  $R_1$ ,  $R_2$  and  $R_3$  each of  $9 \Omega$  are connected in the circuit.

- i) When one resistor is connected in series with the other two resistors which are connected in parallel to each other, the equivalent resistance in the circuit is

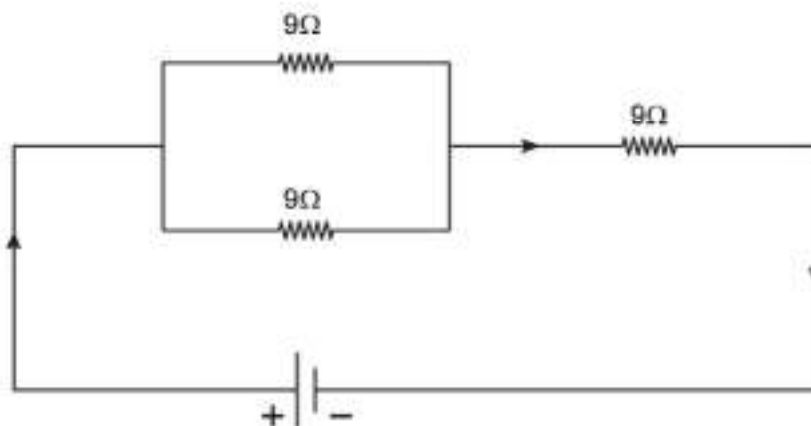



$$\frac{1}{R_p} = \frac{1}{R_1} + \frac{1}{R_2} = \frac{1}{9} + \frac{1}{9} = \frac{2}{9} = 0.22$$

$$\Rightarrow R_p = 4.5 \Omega$$

$$R_s = R_p + R_3 = 4.5 \Omega + 9\Omega = 13.5 \Omega$$

$$\therefore R_{eq} = 13.5 \Omega$$

Thus, by connecting the resistors in this combination, the equivalent resistance in the circuit,  $R_{eq} = 13.5 \Omega$ .

- ii) When one resistor is connected in parallel with the other two resistors which are connected in series with each other, the equivalent resistance in the circuit is

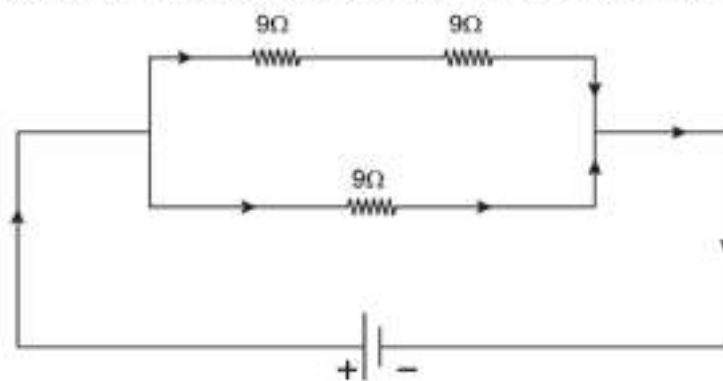

$$R_s = R_1 + R_2 = 9\Omega + 9\Omega = 18\Omega$$

$$\frac{1}{R_p} = \frac{1}{R_s} + \frac{1}{R_3} = \frac{1}{18} + \frac{1}{9} = 0.166$$

$$\Rightarrow R_p = 6\Omega$$

$$\therefore R_{eq} = 6\Omega$$

Thus, by connecting the resistors in this combination, the equivalent resistance in the circuit,  $R_{eq} = 6 \Omega$ .

**OR**

- i) According to Joule's law of heating, heat produced in a wire is directly proportional to

- Square of current ( $I^2$ )
- Resistance of wire ( $R$ )
- Time ( $t$ ), for which current is passed

Thus,

$$H = I^2 \times R \times t \dots \text{(Joule's law of heating)}$$

ii) Current drawn from the first lamp is given by

$$P_1 = V \times I_1$$

$$\therefore I_1 = \frac{P_1}{V} = \frac{100}{220} = 0.45A$$

Current drawn from the second lamp is given by,

$$P_2 = V \times I_2$$

$$\therefore I_2 = \frac{P_2}{V} = \frac{60}{220} = 0.27A$$

Thus the total current drawn by two lamps from the line which are connected in parallel to each other for supply voltage 220 V is,

$$I = I_1 + I_2 = 0.45 + 0.27 = 0.72 A$$

9.

Gland	Hormones	Functions
Thyroid	Thyroxine	Regulates metabolism of carbohydrates, proteins and fats in the body
Pituitary	Growth hormone	Regulates the growth and development of bones and muscles
	Prolactin	Regulates the functioning of mammary glands in females
	Vasopressin	Regulates the balance of water and electrolytes in the body
	Oxytocin	Regulates the ejection of milk during lactation in females
Pancreas	Glucagon	Helps to increase the sugar level in the body
	Insulin	Helps to decrease the sugar level in the body

10.

(i) Equation of the chemical reaction:



(ii) Test to detect the gas:

In the above reaction,  $H_2$  gas is liberated. Its presence can be detected by putting a matchstick at the opening of the test tube.  $H_2$  burns with a pop sound.

(iii) Zn metal reacts with a dilute solution of a strong acid:

Equation of the chemical reaction:



**OR**

(i) The salt is  $\text{NaHCO}_3$ .

(ii) Chemical equation for salt formation:

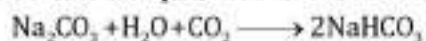

(iii) It is used as an antacid and in the bakery industry.

**11.**

(a) Carbon is a non-metal which is a poor conductor; hence, most of its compounds are poor conductors of electricity.

(b)

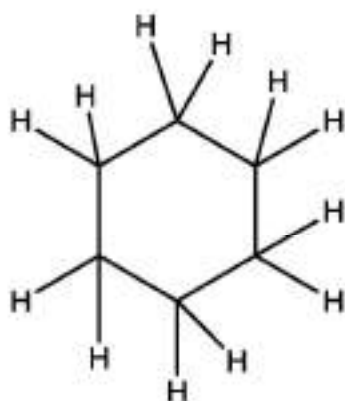

**6-C RING=Cyclohexane**  
It has total 18 single bonds

**12.**

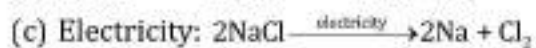
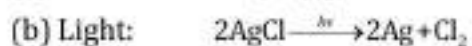
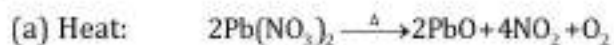

13. Dams are man-made structures constructed across rivers to control, collect and regulate the flow of water.

**Importance and uses of building dams:**

- Regulate the flow of water, which can then be supplied to the people in towns and cities for domestic purposes.
- Useful in flood control and collection of water for large irrigation projects.
- Used to harness hydroelectric power.
- Act as reservoirs of water which can be used for supplying water during the lean season.
- Ensure the storage of water for irrigation and for generating electricity.
- Used to carry water over long distances through canal systems.

**Main problems to be addressed to maintain peace among local people while building dams:**

- Social problems because of displacement of a large number of tribals and peasants who are then rendered homeless.
- No sufficient compensation, rehabilitation or benefits granted from these projects.
- Several environmental problems such as deforestation and loss of biodiversity leading to an ecological imbalance.
- Economic problems due to spending of large amounts of public money without generating proportionate funds.
- Submergence of low-lying adjoining areas of ecological, cultural and social importance for the local population.
- Consideration of local interest and welfare of the people.

14.

(a) **Measures to manage garbage:**

- Throwing the garbage we generate in dustbins
- Separation of wet and dry wastes
- Sorting of waste materials as biodegradable and non-biodegradable
- Composting of biodegradable materials
- Recycling of non-biodegradable materials

(b) **We can adopt the following practices to generate less garbage:**

- Avoid using plastic bags, instead use bags made of cloth and paper.
- Avoid the use of tissue paper, instead use your own cloth napkin.
- Make use of washable cups, mugs and plates instead of disposables.
- Use kitchen wastes to make compost for increasing soil fertility.

(c) **Values instilled by the teacher in students:**

- Sense of responsibility towards the environment
- Social awareness

15.

(a) Factors affecting the resistance of a conductor:

- i) Length of the conductor
- ii) Area of cross-section of the conductor
- iii) Nature of material of the conductor
- iv) Temperature of the conductor

(b) Metals have low resistivity and glass has high resistivity. So, all the metals are good conductors, while glass is a bad conductor of electricity.

(c) The heating elements of electrical appliances are made of alloys because

- i) The resistivity of an alloy is much higher than the metal.
- ii) An alloy does not undergo oxidation or burn easily even if heated up to higher temperature.

16.

(a) **Fleming's left hand rule:**

Stretch the thumb, forefinger and middle finger of the left hand such that they are mutually perpendicular to each other. If the forefinger points in the direction of the field and the middle finger in the direction of the current, then the thumb gives the direction of motion or the force acting on the conductor.

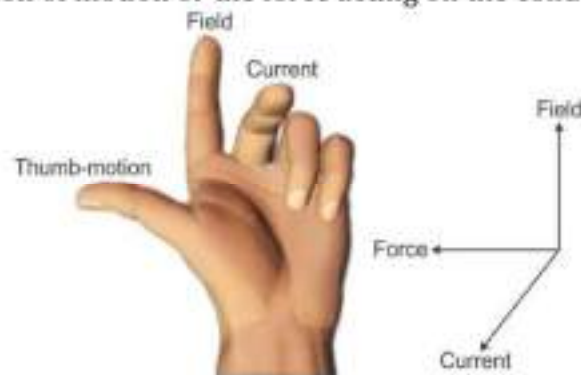

(b) **Principle of working of electric motor:**

A motor works on the principle that when a rectangular coil is placed in a magnetic field and current is passed through it, a force acts on a coil which rotates it continuously.

(c) i) **Armature:**

To convert the electrical energy supplied to the motor to mechanical energy and produce a magnetic field.

ii) **Brushes:**

To make contact with rotating split rings and through them to supply current to the coil.

iii) **Split rings:**

To reverse the direction of current flowing through the coil.

17.

(a) **Functions:**

(i) **Ovary:**

- Produces ova or female gametes.
- Secretes the female hormones oestrogen and progesterone which are responsible for changes in the female body at the time of puberty.

(ii) **Oviduct:**

- Acts as the site for the fertilisation of male and female gametes.
- After fertilisation, the ovum travels down to the uterus through the oviduct.

(iii) **Uterus:**

- Protects and nourishes the developing embryo with the help of placenta.

(b) **Structure and function of placenta:**

- Placenta is embedded in the uterine wall and serves as a connecting link between the mother's body and the baby.
- It is a disc of specialised tissue which provides food and oxygen to the foetus.
- It contains blood spaces on the mother's side and small projections called villi on the foetal side. Here, the mother's blood and foetal blood come in contact with each other.
- It provides a large surface area for the exchange of nutrients and oxygen between the mother and the foetus.
- The foetus gives away waste products and carbon dioxide to the mother's blood for excretion.
- It also functions as an endocrine gland and secretes the hormones necessary to maintain pregnancy.

18.

(a) Extraction of Zn from its carbonate ore:

(i) Concentration: Concentration is done by the gravity separation method.

(ii) Calcination: The ore is calcinated in the absence of air and gets converted to its oxide, i.e. ZnO.  $\text{ZnCO}_3 \xrightarrow{\Delta} \text{ZnO} + \text{CO}_2 \uparrow$

(iii) Reduction: Carbon is used as a reducing agent to reduce ZnO to Zn.

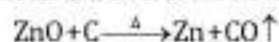

(iv) Electrolytic refining: The impure Zn metal is then purified by electrolysis.

(b) Extraction of Cu from its sulphide ore:

(i) Copper from its sulphide ore can be extracted by heating in air.

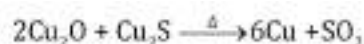

(ii) Refining is then done by electrolysis:

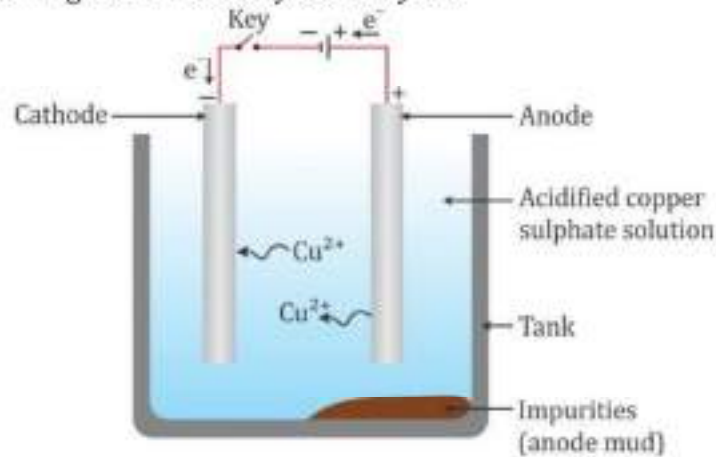

19.

(a) **Components of blood:** Plasma and blood cells (corpuscles)

(b) **Movement of oxygenated blood in the body:**

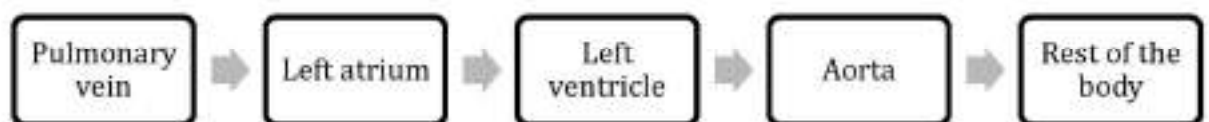

(c) Valves present in between atria and ventricles help to restrict the backflow of the blood from the ventricle to the atrium when the ventricle contracts.

(d) **Differences between artery and vein:**

Artery	Vein
1. It has thick elastic muscular walls.	1. It has thin, non-elastic walls.
2. It does not contain valves.	2. It contains valves to prevent the backflow of blood.
3. Blood flows under high pressure.	3. Blood flows under low pressure.

OR

(a) Excretion is the process of removal of harmful and unwanted substances, especially nitrogenous wastes, from the body.

(b) Nephron is the basic filtration unit of the kidneys.

(c)

(i) **Kidneys:** Form urine

(ii) **Ureter:** Long tube which collects urine from the kidney

(iii) **Urinary bladder:** Stores urine until it is passed out

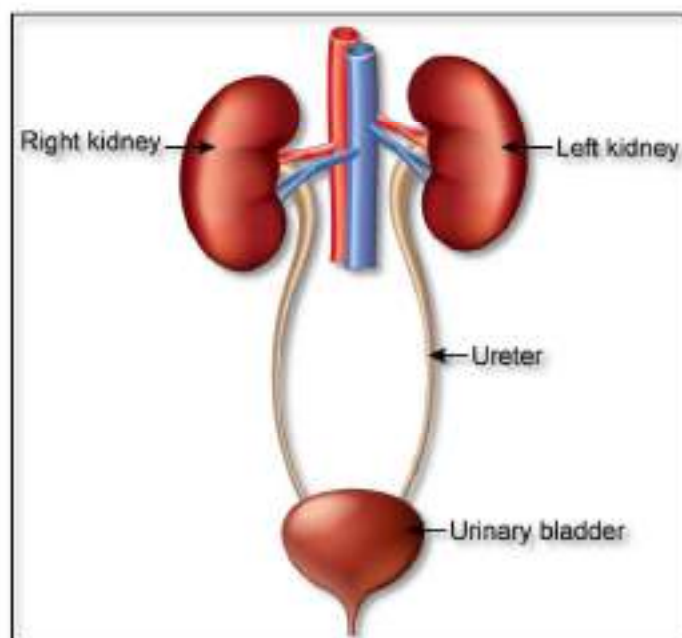

20.

(a)

(i) **Dobereiner's triad:**

Advantage: The three elements of the triad possess similar properties.

Limitation: Some elements which are not similar were grouped into a triad.

(ii) **Newland's octave:**

Advantage: The properties of every eighth element are similar to the properties of the first element.

Limitation: To fit the existing element arrangement, Newlands placed two elements in the same position which differed in their properties.

(iii) **Mendeleev's Periodic Table**

Advantage: The properties of elements in a particular period show regular gradation from left to right.

Limitation: The position of isotopes could not be explained. Isotopes are atoms of the same element having similar chemical properties but different atomic masses. If elements are arranged according to atomic masses, then isotopes should be placed in different groups of the periodic table.

(b) **Mendeleev** showed that atomic number of an element is a more fundamental property than its atomic mass.

(c) **Modern periodic law:**

Properties of elements are a periodic function of their atomic number.



21.a) The boy is unable to see the board which is 3 m away from him.

So, the boy is unable to see distant objects.

This means he is suffering from **myopia or near-sightedness**.

**Causes of myopia:**

- i) Due to a high converging power of lens
- ii) Due to an eyeball being too long

**Methods of correcting myopia:**

- i) Myopia is corrected by using a concave lens.
- ii) The concave lens used to correct myopia is of such a power that it produces a virtual image of the distant objects on the far point of the myopic eye.

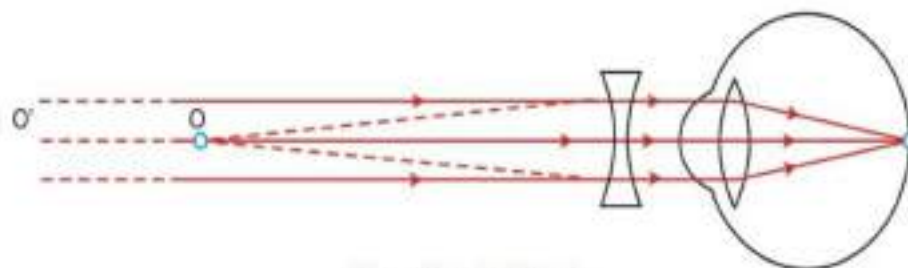

*Correction for Myopia*

**b)**

- i) Stars are luminous objects, and hence, they shine in the night sky.
- ii) If we observe stars in the clear night sky, they appear to change their intensity continuously.
- iii) This change in the intensity occurs due to atmospheric refraction.
- iv) When the light coming from a star enters the earth's atmosphere, it undergoes refraction due to the varying optical densities of air at different altitudes.
- v) So, the intensity of star light entering our eyes increases and decreases.
- vi) Thus, stars twinkle.

**OR**

**a)**

**i) Cornea:** Protective layer of the eye; refraction of light rays entering the eye

**ii) Iris:** Controls the size of the pupil

**iii) Crystalline lens:** Adjusts the focal length and forms an inverted image of the object on the retina

**iv) Ciliary muscles:** Adjust the thickness of the lens

b)

i) During sunrise and sunset, sunlight travels a greater distance through the atmosphere.

ii) Because of this, blue light is scattered more than red light and it directly enters our eyes.

iii) Hence, the sky and Sun appear red during sunrise and sunset.

iv) Atmospheric refraction is the phenomenon of bending of light on passing through the Earth's atmosphere. The reason for this occurrence is that the upper layers of the Earth's atmosphere are rarer compared to the lower layers.

The astronaut who is on the Moon cannot see the Sun reddish during sunrise because the sunlight going towards the Moon does not undergo refraction.

### Section B

22. *Amoeba* reproduces by the process of binary fission. In this method, a single parent cell splits and gets divided into two daughter cells.

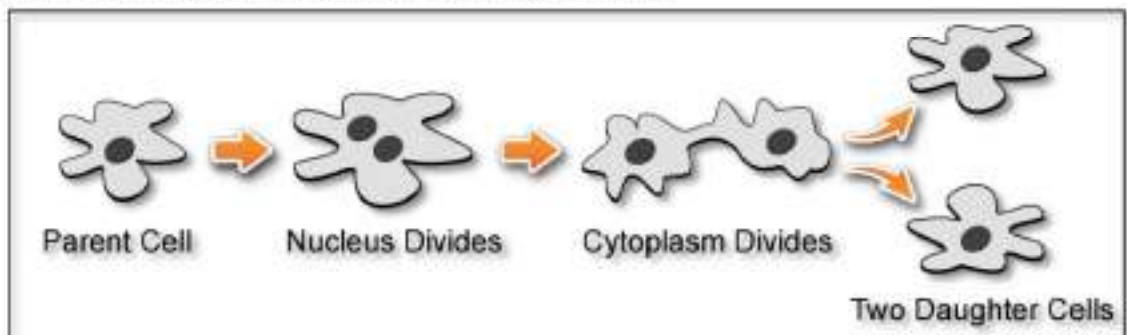

OR

Yeast reproduces asexually by the process of budding. In this method, a bud develops from the body of yeast which gives rise to a new organism.

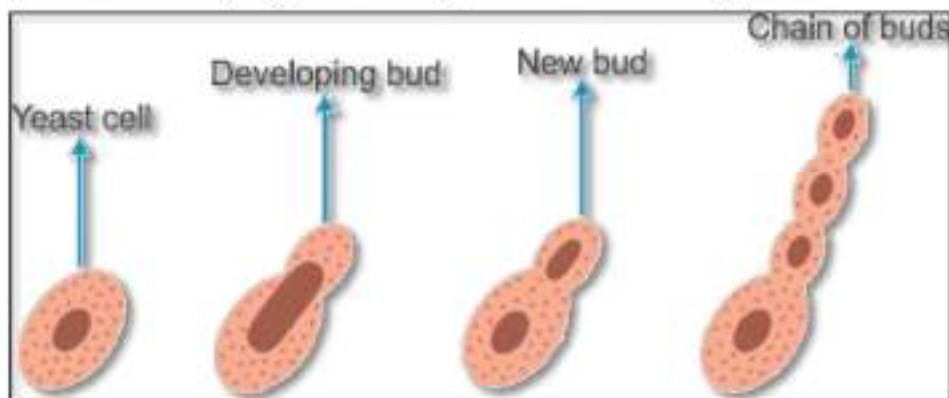

23.

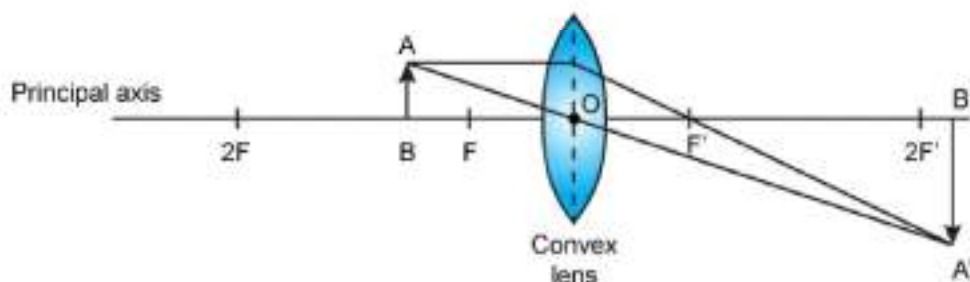

Object size ( $h_1$ ) = 4 cm

Object distance ( $u$ ) = -30 cm

Focal length ( $f$ ) = 20 cm

$$\frac{1}{f} = \frac{1}{v} - \frac{1}{u}$$

$$\frac{1}{+20} = \frac{1}{v} - \frac{1}{-30}$$

$$\frac{1}{v} = \frac{1}{20} - \frac{1}{30} = 0.016$$

⇒ Image distance ( $v$ ) = 62 cm

We know that,

$$m = \frac{\text{height of image } (h_2)}{\text{height of object } (h_1)} = \frac{v}{u} = \frac{62}{-30} = -2.0$$

Thus the approximate ratio of height of image to height of object is -2cm

negative sign denotes that image formed is inverted and real

as the value of magnification is 2, the image is magnified

thus nature of image is real, inverted and magnified

24. Differences in chemical properties:

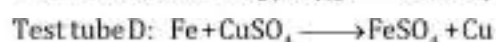
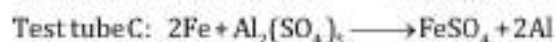
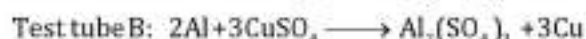
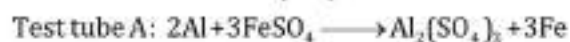

Aluminium is more reactive than iron because aluminium reacts with oxygen in the air to form an oxide which is non-porous. The oxide protects aluminium from further oxidation, so aluminium does not corrode as much as iron.

25. Baking powder ( $\text{NaHCO}_3$ ),

When sodium sulphate is added to barium chloride, it gives a white precipitate of barium sulphate (water insoluble) and sodium chloride (water soluble). This is a double displacement reaction.



26.

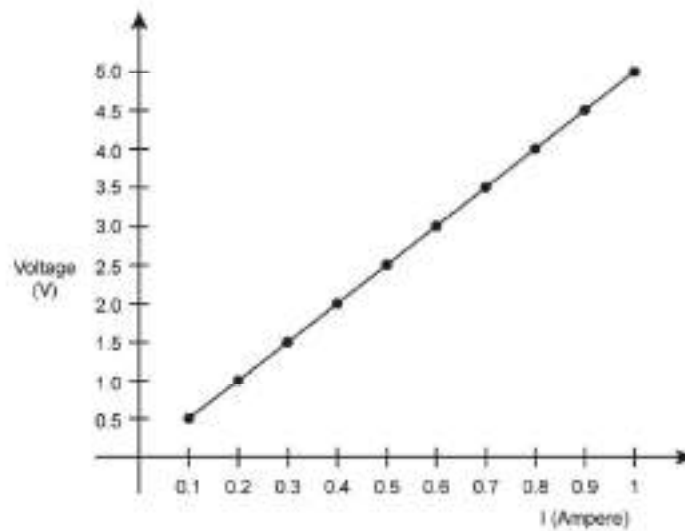

From the graph,

Potential difference (V) = 5 V

Current (I) = 1 A

$$\text{Resistance (R)} = \frac{V}{I} = 5\Omega$$

thus, the resistance of given resistor is 5 ohms.

**27. Steps in the preparation of temporary mount of a leaf peel to observe stomata:**

- Remove a healthy leaf from a potted plant.
- Remove a part of the peel from the lower surface of the leaf. This can be done by folding the leaf over and gently pulling the peel apart using a pair of forceps.
- Place the peel in a watch glass containing water.
- Put a few drops of safranin stain in the watch glass.
- After 2-3 minutes, place the peel on a clean glass slide.
- Put a drop of glycerine over the peel and place a clean coverslip gently over it with the help of a needle to avoid any kind of air bubbles.
- Remove the excess stain and glycerine with the help of blotting paper.
- Observe the slide first under low power and then under high power of the compound microscope.